

AQUA6GEN OWNERS MANUAL

LVM AQ612 : 12 Volt LVM AQ624 : 24 Volt
CHECK LIST

- 1 : Generator
- 1 : Drive Coupling
- 1 : Dee Shackle (8mm)
- 1 : Turbine Shaft Assembly
- 2 : Turbine Blades (90mm)
- 1 : M6 x 20 Stainless Steel Cap Head
- 4 : M6 x 20 Stainless Steel Button Head Screws
- 1 : M6 Stainless Steel Spring Washer

- 2 : M6 Stainless Steel Washers
- 2 : M6 Stainless Steel Washers (18mm Dia.)
- 1 : Tow Rope 19 Metres long
- 2 : Cable/Rope Clamps
- 1 : Mounting Rope 3 Metres long
- 1 : Allen Key 5 mm A/F
- 1 : Allen Key 4 mm A/F
- 1 : 80mm length of Seizing wire

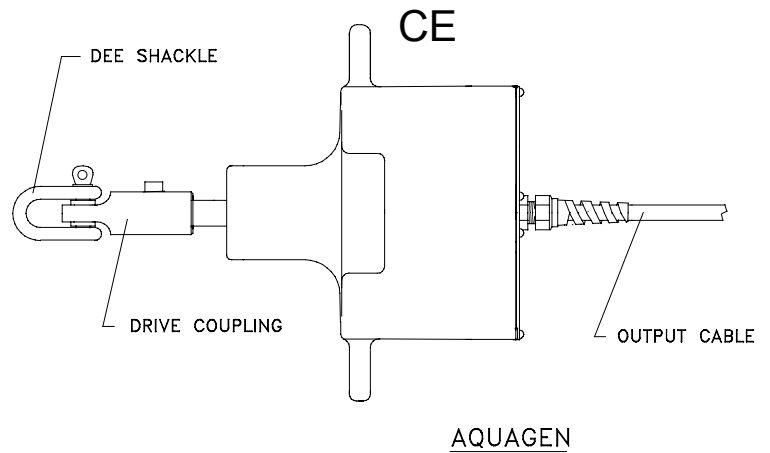

Aqua6gen performance with 90mm turbine blades fitted

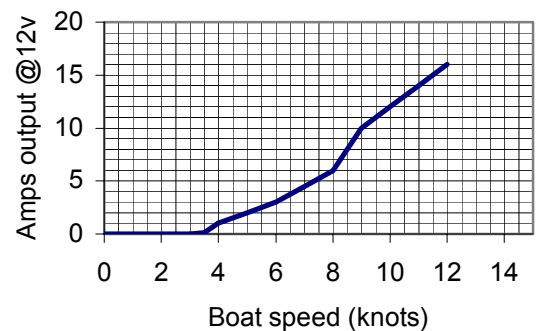

Note: Amps output of a 24v model will be half shown above.

Guarantee

Thank you for purchasing this product. It has been manufactured to exacting standards and LVM Products guarantees that should any defect in materials or workmanship occur within ONE YEAR of the date of purchase we will repair or replace the defective part free of charge.

Damage caused by misuse, failure to follow instructions, negligence, and modification or transit damage will not be warranted.

LVM Products will not be liable for any loss of revenue or any consequential loss or damage to property or persons from any cause whatsoever.

Retain your purchase invoice, as it will be needed in the event of a warranty claim.

What is Not Covered –

- Damage due to improper installation
- Damage due to improper wiring

Please read the manual thoroughly. If you have any questions please contact us at –



Jabsco & Rule, Bingley Road, Hoddesdon, Hertfordshire EN11 0BU
Tel: +44 (0) 1992 450 145 Fax: +44 (0) 1992 467 132

UK

Jabsco UK Sales, Icknield way, Letchworth Garden City, Hertfordshire SG6 1EZ
Tel: +44 (0) 1462 480 380 Fax: +44 (0) 1462 482 422

UK

Jabsco GmbH, Oststraße 28, 22844 Norderstedt
Tel: +49 (0) 40 53 53 73 0 Fax: +49 (0) 40 53 53 73 11

GERMANY

Jabsco Marine Italia S.r.l., Via Tommaseo, 6, 20059 Vimercate, Milano
Tel: +39 039 6852323 Fax: +39 039 666307

ITALY

Discover Jabsco at www.LVM-Ltd.com

MOUNTING

The Aquagen is designed to mount onto the pushpit, using the 3M x12mm Dia. braid on braid rope supplied. It is VERY IMPORTANT to use the rope mounting method as shown in photos 1 – 3 this keeps the unit balanced and allows the Aquagen to swivel and pivot correctly to track the turbine. Failure to use this exact method of mounting will cause vibration and excessive wear on the bronze bushes in the drive coupling. Ensure the knots shown in photo 2 are made on the front face of the unit and the rope goes back through the lower mounting holes of the unit, then tied off to the bottom rail as shown in photos 2 – 3. If only one rail is available fit a deck mounted eyebolt to retain the lower section of the mounting rope.



1. How to tie the knot on the top rail

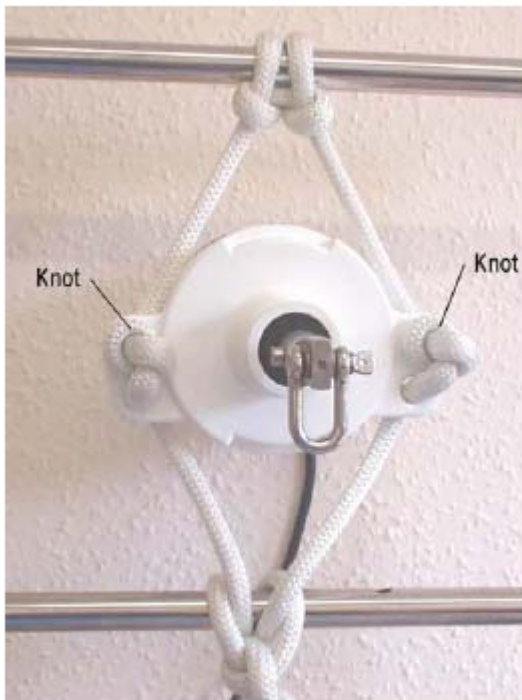

2. Front view of Aquagen correctly mounted



3. Rear view of Aquagen correctly mounted

TURBINE ASSEMBLY

Fit the plastic propeller blades onto the turbine hub using the M6 X 20 Button Head Screws, M6 Stainless steel washers using the Allen key supplied. Note: the large diameter washers are used on the thinnest section of the blade. Photo 4.



4. Turbine Assembly



5. Attaching the tow rope to the drive coupling



6. Attaching the tow rope to the turbine

Photo 5. ATTACHING THE DRIVE COUPLING TO THE AQUAGEN MAIN SHAFT

Align the M6 clearance hole in the drive coupling with the M6 tapped hole in the main shaft. Fit the M6 spring washer under the head of the M6 x 20 Allen bolt. Insert the bolt through the M6 clearance hole in the drive coupling and fully tighten it into the main shaft using the Allen key supplied.

Photo 6. ATTACHING THE TOW ROPE TO THE TURBINE AND DRIVE COUPLING

The Aqua6gen is supplied with 2 off cable/rope clamps these should be used as shown in Photos 5 & 6

ELECTRICAL DATA

Aqua6gen output cable colour Code - The Brown output wire is POSITIVE (+) The Blue output wire is NEGATIVE (-)
 Wire Rating - The output wires of the Aero6gen will require extending. Electrical systems lose energy from the resistance of the wire size used. The larger the wire size the smaller the loss, however larger cross sectional area wires can be costly and in some cases more difficult to source. The following table shows recommended wire sizes, they are based on a 3% and 5% energy loss at an average boat speed of 10 knots. It is recommended a minimum wire size of 2.5 sq mm be used.

Single Wire Length

	0 – 5 Metres		6 – 10 Metres		11 – 20 Metres	
Voltage Drop (%)	3%	5%	3%	5%	3%	5%
12 volt Aqua6gen	6.0 mm ²	4.0 mm ²	16 mm ²	10.0 mm ²	25 mm ²	16 mm ²
24 volt Aqua6gen	2.5 mm ²	2.5 mm ²	4.0 mm ²	2.5 mm ²	6.0 mm ²	4.0 mm ²

A useful wire cross sectional area mm² conversion to AWG
 2.5 mm² = 14AWG, 4.0 mm² = 12 AWG, 6.0 mm² = 10 AWG,
 10.0 mm² = 8 AWG, 16.0 mm² = 6 AWG, 25.0mm² = 4AWG

If the Aqua6gen is connected directly to the battery terminals we recommend a 20 Amp fuse for 12V Models and a 10 Amp fuse for 24v Models is fitted in the brown (positive) wire from the generator to the battery, so that if a dead short occurred it would prevent serious damage to the wiring and the generator. The BROWN OUTPUT WIRE output is connected to the POSITIVE + terminal of the battery. The BLUE OUTPUT WIRE to the NEGATIVE – terminal of the battery.

Thread the Aqua6gen output cable carefully through a deck gland, attach the push - on connectors and covers supplied to the end of the output cable and the end of your extension cable. Observing polarity plug them together. The output wires are then connected to the battery / regulator. See Diagram 5. opposite.

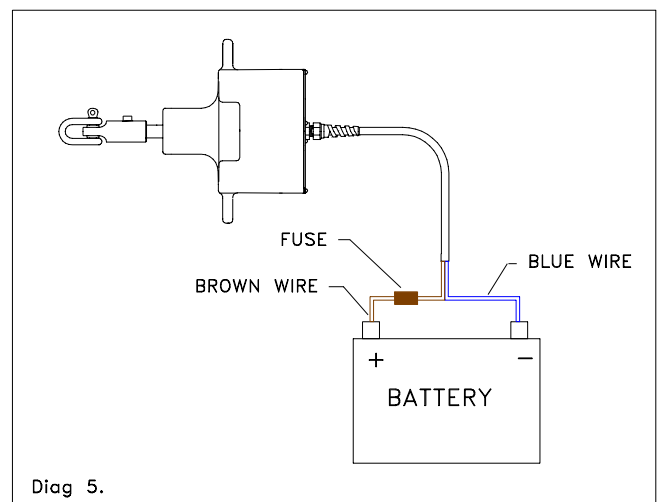

Diag 5.

The BROWN WIRE is connected to the POSITIVE + terminal and the BLUE WIRE to the NEGATIVE - terminal.
VERY IMPORTANT. BE CAREFUL, AS INCORRECT CONNECTION WILL DAMAGE THE RECTIFIER. WARRANTY WILL BE DISCLAIMED.

WARNING : THE AQUAGEN MUST NEVER RUN OPEN CIRCUIT AS HIGH VOLTAGES CAN BE PRODUCED AND THE SUPPRESSION CAPACITORS MAX. VOLTAGE MAY BE EXCEEDED.

VOLTAGE REGULATION

The output wires of the Aqua6en can be connected directly to the terminals of the battery that requires charging, as shown in Fig 5., however, if the terminal voltage of the battery is not continually monitored for over voltage (14.2v for 12v batteries) and (28.4v for 24v batteries) the battery can be seriously damaged. Fitting an LVM voltage regulator will protect the battery from becoming over charged. You may well have chosen a voltage regulator when purchasing the Aero4gen, but we would recommend you look at page 9 SELECTING THE CORRECT LVM VOLTAGE REGULATOR to make sure you have purchased the correct unit.

You may also consider installing an ammeter, voltmeter or an amphour meter – all are available from LVM Products part number as follows -

(LVM67) 0 –20A Ammeter, (LVM69) 0-15v dc Voltmeter, (LVM200) Digital Amp Hour Meter.

OPERATING INSTRUCTIONS

The towrope with the turbine attached should be stored in a neat coil close to the Aquagen.

Once under way in deep water the turbine/tow rope can be payed out. It is safer to do this at around 1-2 Knots as the rope will start to turn as soon as it enters the water. The turbine is designed to surface at the following speeds

Small 90mm turbine blade - 14 knots

Retrieving the turbine/tow rope can be achieved in two ways

1. Slow yacht/boat to 1-2 Knots, then pull in towrope.

2. Make a tack to turn the yacht/boat at 90 Deg. to slow it down and bring along side the turbine/tow rope.

When pulling in the towrope it is very important that it is untwisted and coiled neatly ready to use again.

Note: If for any reason the turbine surfaces before 14 knots when using the 90mm blades

(this may be caused by your particular hull shape of the yacht creating an underwater wash effect) add one or two 25mm propeller shaft anodes should be fitted to the turbine shaft close to the turbine hub, increase the length of the tow rope.

VERY IMPORTANT

If you do not intend to use the LVM voltage regulator with the Aquagen it is extremely important that a similar type of regulator is used ie. It must be a shunt diverting type regulator that always keeps the Aquagen on load.

YOU MUST NEVER USE A REGULATOR THAT SIMPLY TURNS OFF AND ON THE OUTPUT OF THE AQUAGEN WHEN THE BATTERY IS FULLY CHARGED. (THIS CAN LEAVE THE AQUAGEN IN AN OPEN CIRCUIT CONDITION WHICH WILL ALLOW THE TURBINE TO ROTATE AT VERY HIGH SPEED AND DAMAGE THE UNIT)

MAINTENANCE

1. Check drive shackle bronze bushes for wear. Apply a little marine grease to the bronze bushes from time to time. Typical life of the bronze bushes 3,000 – 7,000 nautical miles.

2. Check the tow rope for wear at intervals, particularly the area around the Dee Shackle and Eye bolt on the turbine shaft. By cutting 1 to 2 inches off the rope a new section can be created.

3. Check tightness of the Dee Shackle pin.



Drive coupling assembly

TROUBLE SHOOTING

The AQUA6GEN generator unit is design to give many years of reliable service as it contains really only one moving part and one electronic component; they are the permanent magnet rotor and a 3 phase rectifier. The only parts that can wear are the main bearing ball races.

SIMPLE TEST

A simple test to prove there is an output voltage from the Aqua6gen can be carried out whilst the Aqua6gen is in it's working position. Disconnect the Aqua6gen output cable from the battery, or the TB regulator if fitted. With the towrope disconnected turn the main shaft, it should turn freely (Note : There will always be a slight resistance felt this is the cogging effect of the generator) , then touch the two output leads together (shorting them) the main shaft should now be noticeably more difficult to turn. If this does not happen, check that your extension wire connection from the actual Aqua6gen output cables are not corroded or have become disconnected. If there is a fuse fitted in the output cable check it has not blown.

The following tools and equipment will be needed to carry out tests and repairs to the Aqua6gen

A multimeter which can read 0 - 100 volts DC, measure resistance, have a diode test, and a continuity (buzzer test).
Pozi drive screwdriver.
Circlip pliers.
Soldering iron and solder.
Hammer.
Piece of hardwood, and a brass rod 12mm diameter X 250mm long or similar.
For pivot bearing replacement, a bench vice will be required.

MEASURING OUTPUT VOLTAGE

If you have a lathe or some other means of turning the main shaft at a known RPM a 12v model produces 0.036v per rev. and a 24v model 0.072v per rev.

If no voltage is present, check that your extension wire connection from the actual generators output cables are not corroded or have become disconnected. If there is a fuse fitted in the output cable check it has not blown. Check output voltage again at the generators actual output cable. If there is still no voltage output, go to the instructions and tests listed under heading NO OUTPUT.

REDUCED OUTPUT

1. Check turbine blades are not damaged.
2. Check towrope is not kinked and twisted.
3. Check main shaft of Aquagen turns freely. Note : There will always be a slight resistance felt this is the cogging effect of the generator.
4. If the output from the Aquagen has been connected to the battery the wrong way round (reverse connection) the rectifier will be damaged, but still may give a reduced output. (Replace rectifier).

NO OUTPUT

1. Using a multimeter check continuity of output extension cable, and connectors.
2. Check fuse.
3. Remove the generator from mounting,. Remove the rear cover (6 off screws) and hinge back cover. A component called a rectifier that converts the 3 Phase A/C output voltage of the stator into D.C volts is mounted on the inside of the cover. (Note later models have also suppression capacitors soldered to the rectifier.)
Disconnect the 3 push fit connectors (output wires from stator) which are attached to the centre terminals of the rectifier. No need to remember which order or terminal they come from, as they can fit on any of the 3 centre terminals.
Using a multimeter set on resistance measurement (ohms) check the resistance in turn of the of 3 output wires (in pairs) from the stator. They should read 0.9 ohms 12v model, 3.5 ohms 24v model.

CHECKING A/C OUTPUT VOLTAGE OF STATOR

Set the multimeter to read A/C volts, attach test leads to the 3 off stator output wires (in pairs) then turn the main shaft of the generator by hand (any direction) small voltage should be indicated on the multimeter.
Check the stator and suppression capacitors do not look burnt or overheated. Check tightness of stator retaining screws.
If at any time the generators output leads have ever been connected to battery terminals the wrong way round, or the generator has been struck by lightning then the rectifier may be have been damaged.

RECTIFIER TEST

Readings taken of a Good Rectifier.

Set a multimeter to diode test, then check: -

1. Disconnect all connectors from the rectifier.
2. Attach the red test lead from multimeter to the + plus terminal of the rectifier, attach the black test lead to the - negative terminal. RESULT No Reading.
3. Reverse the test leads i.e. attach the red test lead to the - negative terminal of the rectifier then the black test lead to the + plus terminal. RESULT 0.8 - 0.9 volts
4. Connect the test leads to the 3 centre terminals of the rectifier in pairs. RESULT No Reading.

Readings taken of a Faulty Rectifier.

1. Disconnect all connectors from the rectifier.
2. Attach the red test lead from multimeter to the + plus terminal of the rectifier, attach the black test lead to the - negative terminal. RESULT 0 Volts
3. Reverse the test leads ie. attach the red test lead to the - negative terminal of the rectifier then the black test lead to the + plus terminal. RESULT 0 Volts
4. Connect the test leads to the 3 centre terminals of the rectifier in turn in pairs. RESULT 0 Volts

If in doubt about the condition of the rectifier, replace with a new one. Refit the 3 off 3 phase stator leads to the centre terminals of rectifier.

Set the multimeter to read DC. volts. Attach the red test lead of the multimeter onto the + plus terminal of the rectifier, then the black test lead onto the - negative terminal. Turn the main shaft of the generator by hand (any direction) this should indicate a voltage on the multimeter. Refit Red and Black DC. output leads from the rectifier. Refit rear cover using a new gasket make sure all wires are clear of the rotor.

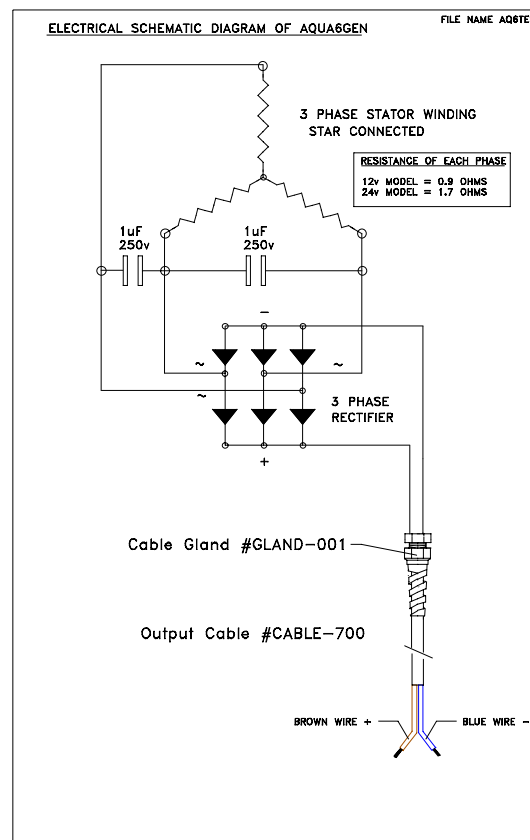
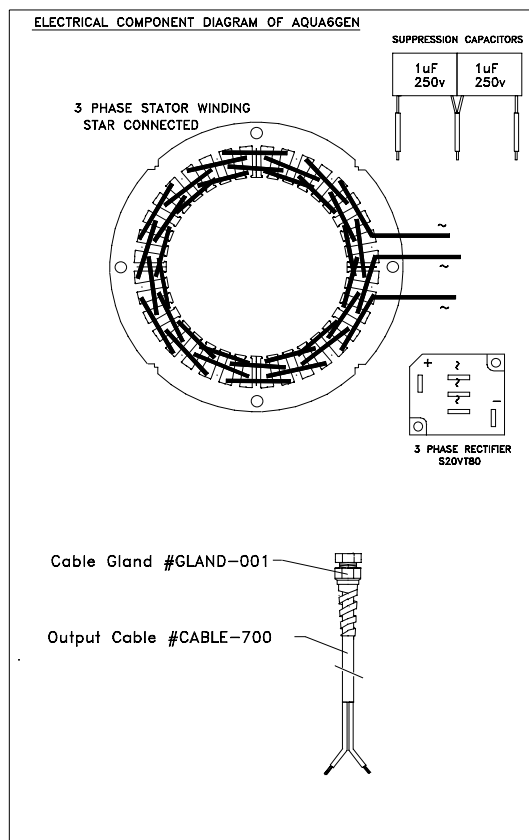

KNOCKING/SCRAPING SOUND ONCE PER REVOLUTION

Whilst the generator is in it's working position, check that the M6 allen screw which retains the drive coupling assembly to the main shaft is fully tightened.

Remove rear cover and check the condition of the rotor, it may be rubbing on the stator.

Inner main bearing could be worn, check for axial and radial movement. Check the tightness of the 4 off M5 stator retaining screws, this can cause a noise if slightly loose.

GENERAL MECHANICAL CONTINUOUS NOISE

Remove the towrope and check axial and radial play in the main front bearing. Remove rear cover and check inner main bearing in the same manner. If large amount of play is found replace main bearings.

Follow instructions listed REPLACING MAIN BEARINGS.

GENERAL ELECTRICAL VIBRATION NOISE

It is normal for the Aqua4gen to produce a very slight magnetic cogging vibration when rotating, and an electrical vibration whilst charging. This noise will be greatly amplified if the Aqua4gen is mounted on a very hollow section of a yacht/boat.

INSTRUCTIONS FOR REMOVING AND REPLACING MAIN BEARINGS

Parts required:	2 off - Main bearings	LVM Part No. Bearing 783
	1 off – Main shaft water seal	LVM Part No. Seal 650
	1 off - Rear cover gasket	LVM Part No. Gasket 548
	2 off - Circlips 15mm	LVM Part No. Circlip 862
	6 off - Rear cover retaining screws	LVM Part No. Screw 664
	1 off - Small amount of Loctite 638 in tube.	

Tools required: Hammer, Circlip pliers, Pozi drive screwdriver, Piece of hardwood, and a brass rod 12mm diameter X 250mm long or similar.

1. Disconnect output leads, and remove Aqua4gen from mounting.
2. Remove the main shaft water seal (pierce seal front face with screw driver and lever out.
3. Remove the front 15mm circlip on the main shaft.
4. Remove 6 off self-tapping screws retaining the rear cover.
5. Place a piece of hard wood on a concrete floor. Holding the Aqua4gen with the rear cover held back and main shaft downwards, lift and force downwards the generators main shaft onto the piece of hard wood. This should displace the main shaft inwards. Alternatively the main shaft can be pressed out, or hammered out, but take care not to bruise the end of main shaft.
6. The main shaft/ rotor assembly should now have moved inwards into the main housing.
7. Using a piece of brass rod, or similar, so as not to damage the end of the main shaft - tap the shaft through both the bearings and remove rotor assembly from the rear of the main housing.
8. Having removed the rotor from casting. Check the main shaft for wear, particularly the areas the main bearings are positioned. If the shaft wear is found to be excessive a new shaft will have to be fitted. Contact LVM Products.
9. Remove the large internal circlip which is located in front of the main outer bearing, then using a brass rod and a hammer knock out the main bearings from the casting.
10. Refit new main bearings using a little Loctite Bearing Fit smeared on the O.D. of the bearings.
11. Refit large internal circlip in front of main outer bearing (this circlip is acts as a spacer for the water seal)
12. Clean the main shaft, then clean the rotor magnet with sellotape (sticky side) to remove small pieces of steel pickup.
13. Smear a little Loctite Bearing Fit onto the main shaft close to the rotor, and in the bore of the outer main bearing.
14. Insert the main shaft/rotor assembly into the generator main bearings. **WARNING!** The rotor magnets are very powerful and will quickly draw the assembly into the stator. When the main shaft/rotor assembly is fully inserted check it rotates without rubbing.
15. Smear a little Loctite Bearing Fit on the outer main bearing inner race to shaft. i.e. between the O.D. of the shaft and the I.D. of the inner race. Push the main shaft in and out a little to spread the Loctite between the outer main bearings bore and the main shaft.
16. Fit new 15mm circlip on main shaft.
17. Fit new main shaft water seal (grease well on assembly)
18. Refit rear cover using a new gasket, make sure all internal wiring is clear of the rotor.

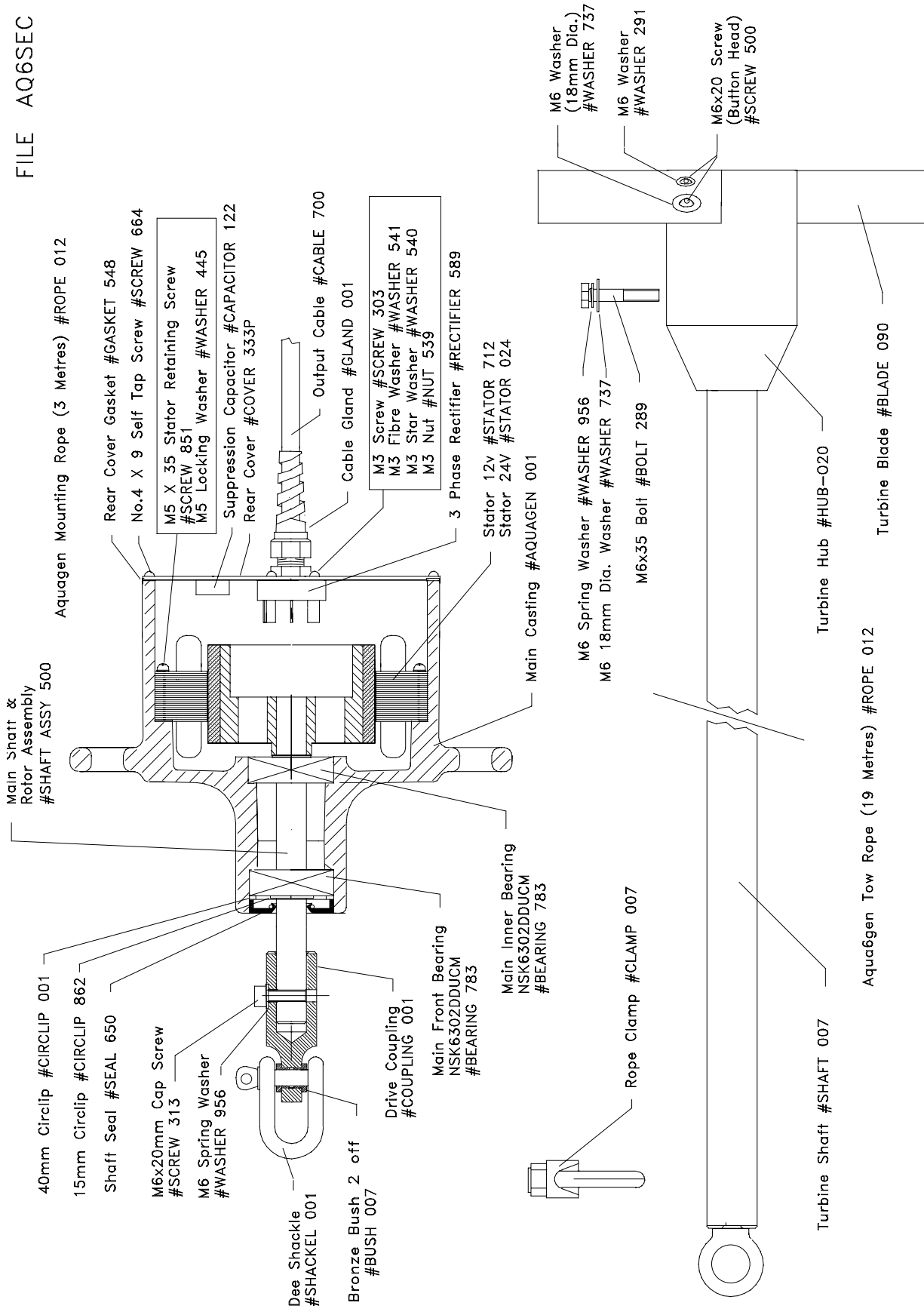

AQUA6GEN PARTS LIST

SELECTING THE CORRECT LVM VOLTAGE REGULATOR

The output of the Aquagen can be simply connected directly to the terminals of the battery that requires charging, however, if the terminal voltage of the battery is not continually monitored for over voltage (14.2v for 12v batteries) and (28.4v for 24v batteries) the battery can be seriously damaged. Fitting an LVM voltage regulator will protect the battery from becoming over charged.

TEMPERATURE COMPENSATION - This additional feature is available on all LVM regulators. If the battery is located in a building where the ambient temperature is always around 20 deg.C then standard regulators can be used. However if you intend to locate a battery where temperatures may go down to freezing and perhaps rise to tropical temperatures then you should install a regulator that is fitted with a temperature compensation circuit. This automatically allows the battery to be charged at a higher voltage as the temperature drops, and a lower voltage if the temperature increases. Simply add (-T) after the LVM Product No. ie. 4TB12 -T.

The regulator suitable for the Aqua4gen –

Twin battery regulator – LVM product No. 4TB12, 4TB24 - These units are connected between the output of the Aquagen or Solargen module and the battery terminals. They control the actual output voltage of Aquagen or Solargen by diverting power to a high wattage wire wound dump resistor when their output voltage reaches 14.2v (12v systems) or 28.4 (24v systems). They have two schottky blocking diodes built into the regulator which enables them to monitor and control the charge to two batteries totally independent of each other, therefore making it ideal for separate charging of engine starting and domestic batteries. The battery with the lowest terminal voltage will be charged first, then gradually when both batteries become fully charged the Aquagen or Solargen modules output is automatically diverted to the dump resistor, this does two things it stops the batteries over charging and keeps the Aqua4gen always on load.

Note: This regulator draws NO standby current from the battery.

Also available from LVM Products are Diode Units – LVM product No. 4DU, 6DU

The 4DU when combined with a 2TB or 4TB regulator enables one additional battery to be charged.

The 6DU when combined with a 4TB regulator enables two additional batteries to be charged.

The Aqua6gen and a Solargen modules output may often be combined, the table below shows the recommended regulator for various systems. Note: Two batteries wired in parallel are classed as one independent battery. Having selected the recommended regulator model from the table simply add the voltage required ie. 4TB12 for a 12v system or 4TB24 for a 24v system. Basic wiring diagram are shown on page 10. If you cannot find your particular system or application within the table or require full wiring diagrams please check our web site www.lvm-ltd.com or call our sales office who will e-mail, fax or post you copies.

VOLTAGE REGULATOR TABLE

SYSTEM	Number of independent batteries to be charged			
	1	2	3	4
1 x Aqua6gen	4TB	4TB	4TB + 4DU	4TB + 6DU
1 x Aqua6gen + 5w Solargen panel	4TB	4TB	4TB + 4DU	4TB + 6DU
1 x Aqua6gen + 10w Solargen panel	4TB	4TB	4TB + 4DU	4TB + 6DU
1 x Aqua6gen + 17w Solargen panel	4TB	4TB	4TB + 4DU	4TB + 6DU
1 x Aqua6gen + 25w Solargen panel	4TB	4TB	4TB + 4DU	4TB + 6DU
1 x Aqua6gen + 25w+10w Solargen panel	4TB	4TB	4TB + 4DU	4TB + 6DU
1 x Aqua6gen + 25w+25w Solargen panel	4TB	4TB	4TB + 4DU	4TB + 6DU

