

# Aerator Pump 500

4108, 4108 A

## MOUNTING INSTRUCTIONS

FORM NUMBER 69280

**attwood**

Attwood  
Subsidiary Steelcase Inc.

1016 N. Monroe Street  
Lowell, MI 49331-0260  
I/R 9/94

### FEATURES

The Aerator Pump 500 is recommended for fishing boats with built-in livewells. Pumping capacity at open flow is 500 gallons per hour.

This pump is sealed and, therefore, submersible. **However, the electrical wire connections must not be submerged.** For extra protection, coat butt joints and adjacent wire ends liberally with liquid electrical tape such as MDR or Starbrite.

The Aerator Pump 500 has a flat bottom and two mounting feet to permit remote installation away from the transom as long as pump chamber is below the water line ... or it can be installed conventionally through the transom.

This pump is designed to be used with 3/4" I.D. hose and 3/4" thru-hull fittings.

**Please pay special attention to instruction number six. It is important to use the correct marine sealant.**

*Attwood marine hardware, navigational lighting, bilge pumps, and other marine accessories are specified more than any other brand by America's best-known boat manufacturers as original equipment. Look to Attwood for quality replacement parts and add-on marine accessories.*

**WARNING:** Do not attempt to install, adjust, service, or remove this product while the boat is in the water.

### CAUTION

**To prevent personal injury, always disconnect electrical connection when installing or servicing this product.**

Although the pump is completely submersible, the lead wires must terminate in a waterproof connection, and must be mounted high and dry to prevent premature pump failure. Route the wires to a point above the highest anticipated water mark.

**To prevent damage to the pump motor, the aerator pump circuit must be fused with a 2-amp fuse.** If the fuse blows, turn the pump switch to the OFF position. **REMOVE THE BOAT FROM THE WATER.** Remove the three screws from the pump body and check the impeller to ensure it is free of debris. Make sure the O-ring is in place. Once the impeller chamber is cleared, re-assemble the pump body (do not overtighten the three screws), replace blown fuse, and test the pump.

### TOOLS AND MATERIALS REQUIRED FOR INSTALLATION:

1. Suitable length of 3/4" I.D. reinforced hose (**Do not use bilge pump hose or unreinforced hose that could leak, split, or puncture.**)
2. Hose clamps suitable for 3/4" hose
3. ON/OFF dash-mounted control switch
4. In-line fuse connector and a 2-amp fuse

5. Two #8 stainless steel pan-head screws (to be used if pump is not mounted through the transom)
6. Wire butt connectors for 16-gauge wire
7. Insulated spade terminal connectors for 16-gauge wire
8. Polyurethane marine sealant for thru-hull fitting
9. Suitable means to waterproof electrical connections
10. Power drill with 1/32" to 1-1/16" diameter bit for the thru-hull connector
11. Screwdriver
12. Liquid electrical tape such as MDR or Starbrite.

### OPTIONAL MATERIALS:

1. 1/2" thick marine plywood block for transom mounting, if transom is less than 1/2" thick
2. 1/2" thick marine plywood block or wedge at least 6" square for remote installation
3. Waterproof adhesive (epoxy, silicone adhesive, fiberglass resin) for mounting blocks
4. 16-gauge wire (brown and black)
5. Thru-hull fitting with strainer (Attwood part number 3886)
6. Hose connector (Attwood part number 3887)

### THRU-TRANSOM INSTALLATION INSTRUCTIONS:

1. Install the 90-degree fitting to the pump outlet making sure the gasket is in place. Turn the fitting down until it makes contact with the gasket. Continue to rotate the fitting until it reaches the desired discharge direction and provides a watertight seal.
2. With the boat out of the water, select a suitable location at least 2" below the water line at the transom to mount the pump (see Figure 1). It is not necessary to locate the pump on the boat centerline.

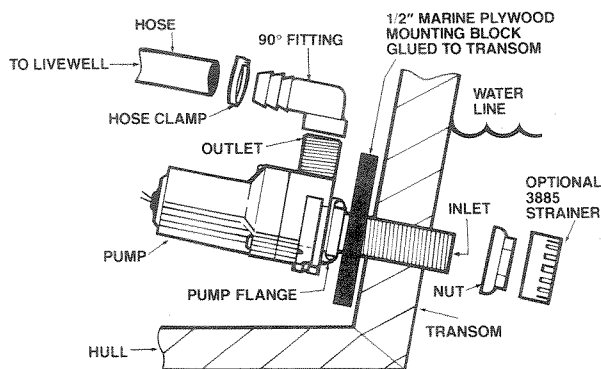

FIGURE 1

3. Make sure transom is at least 1/2" thick. If not, glue a 1/2" thick marine plywood block to the transom using a waterproof adhesive.
4. Make sure there is enough room inside the hull for the pump and hose before you drill!
5. Drill a 1-1/16" hole through the transom.
6. Apply a generous bead of polyurethane marine sealant (Boat-Life Life-Seal® sealant) to the nut and to the threaded side of the pump flange prior to installing the pump. **Do not allow sealants containing acetic acid (smells like vinegar), such as silicone rubber sealant, to come in contact with the plastic thru-hull connector. They can attack the plastic causing the thru-hull connector to crack resulting in pump failure.**
7. Install thru-hull pump fitting through the transom and attach nut firmly. **CAUTION:** Do not overtighten nut.
8. For a neat appearance, cut off any extra threaded fitting within one thread of the nut. If optional strainer (Attwood part number 3885) is to be used, cut off 3/8" beyond the nut and screw on the strainer.

- For best performance, the pump must be horizontal with the outlet pointed straight up (see Figure 1).
- Connect a 3/4" I.D. hose from the 90-degree pump outlet to the aerator head in the livewell.  
USE A HOSE CLAMP AT THE END OF EACH HOSE CONNECTION TO PREVENT LEAKAGE.  
For best performance, make sure there are no dips in the hose that can trap water when pump is shut off.
- Using the full length of wire provided (and additional wire, if necessary), wire pump as shown in the wiring diagram (Figure 2). Make sure it is a 12 volt DC battery power source only. Higher voltage will damage pump motor.

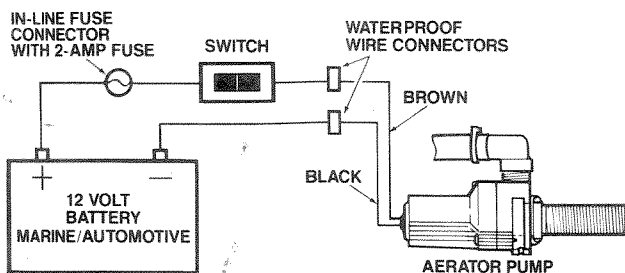

FIGURE 2

- Using in-line connectors for 16-gauge wire, splice fuse holder into positive lead (brown) in a location easily accessible for changing fuses. NOTE: Be sure to use a 2-amp fuse.
- Install a dash-mounted ON/OFF control switch.

#### REMOTE LOCATION INSTALLATION INSTRUCTIONS:

- With the boat out of the water, select a location at least 2" below the water line at the transom to install the thru-hull connector (Attwood part numbers 3873, 3873A, 3877, 3886, or 3896). (See Figure 3) Pump chamber must be below water level.

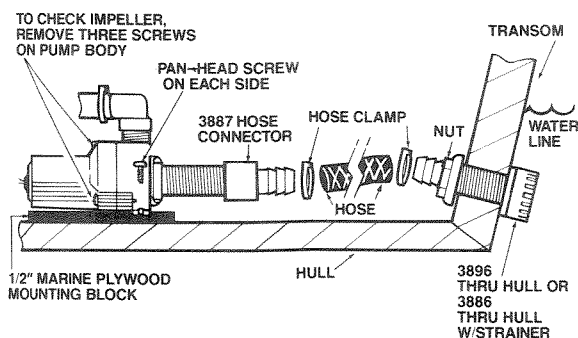

FIGURE 3

- Drill a 1-1/16" hole through the transom.
- Apply a generous bead of polyurethane marine sealant (Boat-Life Life-Seal® sealant) to the nut and to the threaded side of the pump flange prior to installing the pump. **Do not allow sealants containing acetic acid (smells like vinegar), such as silicone rubber sealant, to come in contact with the plastic thru-hull connector. They can attack the plastic causing the thru-hull connector to crack resulting in pump failure.**
- Install thru-hull connector through the transom and screw nut on to firmly hold thru-hull in place. CAUTION: Do not over-tighten nut.
- Glue 1/2" thick marine plywood block or wedge (approximately 6" square) to the floor of the boat at a point in line with the thru-hull connector.
- Mount the pump to this plywood block or wedge by drilling 1/8" pilot holes at the location of the two mounting feet. **DO NOT DRILL THROUGH BOAT BOTTOM.** Make sure pump is horizontal and pump outlet is pointed straight up (see Figure 3).

Using two suitable length #8 stainless steel pan-head screws, secure pump into place. **DO NOT ALLOW SCREWS TO PENETRATE HULL OF BOAT.**

- Install Attwood hose connector (part number 3887) to the intake of the pump (see Figure 3).
- Connect a length of 3/4" I.D. hose from the thru-hull to the hose connector on the pump.  
USE A HOSE CLAMP AT EACH END OF THE HOSE TO PREVENT LEAKAGE.

COMPLETE THIS INSTALLATION BY FOLLOWING STEPS 11 THROUGH 13 OF "THRU-TRANSOM INSTALLATION INSTRUCTIONS"

#### CARE AND MAINTENANCE

Occasionally check your pump to be certain debris is not jamming the impeller. Careful attention will provide outstanding pump performance.

Pump can be disassembled by simply removing the three screws from the pump body. **WARNING: Do not attempt to disassemble pump or loosen any screws, nuts, or hose connections while boat is in the water. Uncontrollable flow of water into the boat could occur.**

Remove all debris that has accumulated in pump chamber and around impeller.

Inspect the impeller to ensure that it is firmly attached to shaft and is not cracked or broken.

Make sure the O-ring is in place and reassemble the pump body by replacing the three screws.

Periodically check the electrical connections to ensure they are waterproof and mounted high and dry.

All plumbing must be secure and protected from wear and damage. Remember, most of the pump and the plumbing is below water level and any leak will allow water to enter the boat.

### ATTWOOD LIMITED WARRANTY

ATTWOOD CORPORATION, Lowell, Michigan 49331, ("ATTWOOD"), warrants to the original consumer purchaser that this ATTWOOD aerator pump will be free from defects in material and workmanship, under normal use and service, for a period of twelve (12) months from the date of original purchase. This limited warranty is expressly conditioned on the consumer purchaser's use of the aerator pump in conformance with the instructions enclosed with the product. This Limited Warranty is void if the aerator pump has been damaged by accident or unreasonable use, neglect, improper service, or other causes not arising out of defects in material or workmanship. ATTWOOD will not repair or replace the aerator pump or be responsible for any damages or injury to persons or property resulting from any attempt by the consumer purchaser or by any unauthorized service personnel, to repair, adjust, assemble or otherwise tamper with the aerator pump, or its wiring, control, or components. Excluded from this warranty are batteries and fuses.

The exclusive remedy of the consumer purchaser in the event that the product does not meet this express Limited Warranty is to return the aerator pump to ATTWOOD at the above address, postage prepaid and insured, for repair or replacement, at the option of ATTWOOD, without charge to the consumer purchaser. The acceptance by ATTWOOD of any aerator pump returned shall not be deemed an admission that such pump is defective or in violation of any warranty, and if ATTWOOD determines that the product is not defective, the aerator pump shall be reshipped to the consumer purchaser at such purchaser's expense. **IMPORTANT: FOR THIS WARRANTY TO BE EFFECTIVE, ATTWOOD MUST BE SUPPLIED WITH PROOF OF THE ORIGINAL PURCHASE DATE OF THE AERATOR PUMP.**

NO EXPRESS OR LIMITED WARRANTY, INCLUDING IMPLIED WARRANTIES OF MERCHANTABILITY AND FITNESS SHALL EXTEND FOR ANY PERIOD OF TIME GREATER THAN TWELVE (12) MONTHS FROM THE DATE OF ORIGINAL PURCHASE OF THIS PRODUCT. Some states do not allow limitations on how long an implied warranty lasts, so the above limitations may not apply to you.

Under no circumstances will ATTWOOD be liable for any lost profits, incidental or consequential costs, expenses or damages. THERE IS NO GUARANTEE OF THIS PRODUCT OTHER THAN AS SPECIFIED HEREIN; THIS LIMITED WARRANTY IS EXPRESSLY MADE IN LIEU OF ANY AND ALL OTHER WARRANTIES, EXPRESSED OR IMPLIED. The limitations on liability for lost profits, incidental or consequential costs, expenses, or damages shall survive any failure of essential purpose of this limited warranty. Some states do not allow the exclusion or limitation of incidental or consequential damages so the above limitation or exclusion may not apply to you.

This warranty gives you specific legal rights, and you may also have other rights which vary from state to state.

**attwood**