

AUTOMAC MANUAL

CONTAINING

ALTERNATOR FILE

INTRODUCTION

AutoMAC is a manual alternator control with an additional automatic feature which prevents excessive charging current and battery overcharging, covered by US patent. The AutoMAC lets you select alternator output current for battery charging by turning the control knob. Alternator output current is displayed on the AutoMAC ammeter. If you forget the AutoMAC, it will switch itself off automatically when the batteries are full. When it is switched off by hand or by its automatic circuit, the alternator continues to operate with its own voltage regulator, and the alternator output continues to be shown on the AutoMAC ammeter. The AutoMAC can be used with all standard brands and models of alternators in use on automotive and marine engines. Maximum field current is 4 Amperes.

HOW THE AutoMAC WORKS

The AutoMAC is connected to the field coil of the alternator. When it is switched on, the AutoMAC operates parallel to the voltage regulator and supplies field current to the alternator. A slight increase of the alternator output voltage will result in a substantial increase in output current. During this time, in response to the sensed voltage, the voltage regulator ceases to supply any field current. But when the AutoMAC is switched off, the voltage regulator operates in its normal fashion.

During battery charging, the AutoMAC monitors the voltage of the 12 Volt system which depends on the state of charge, size of the batteries, and on the magnitude of charging current. The automatic off circuit is triggered, and the red cutoff light is turned on when the batteries have become fully charged, or when the selected charging current has become too high for the size or capacity of the batteries at their present state of charge. The AutoMAC is designed to remain out off unless intentionally reset, or until the engine has been shut down and the power disconnected.

HOW TO PROCEED

Please read these instructions first. Note the ALTERNATOR FILE section of this booklet, which shows examples of the many alternators in use. Find out which brand of alternator is used on your engine, and whether it has an internal or attached voltage regulator or (rare) an external, remote voltage regulator. Connect a new field wire to the alternator by following the detail in the ALTERNATOR FILE. Connect the ammeter of the AutoMAC but DO NOT connect AutoMAC to alternator yet. Test the ammeter: it shows some alternator output current whenever the engine is running. Now test the new field wire. At the same time, you will verify the type of alternator which we call type P (regulator on the Positive side of field coil) or N (regulator on the Negative side of field coil). (This is our designation. Not related to any letters on alternator label, not related to negative ground.) Only then connect alternator and AutoMAC, following either the type "P" or type "N" wiring sketch in this booklet.

INSTALLATION

An essential part of the installation is that you read, understand and follow the instructions in this manual. This applies even if you have someone else install the AutoMAC for you. Note the ALTERNATOR FIELD section which is a part of the installation instructions.

Select a location for the AutoMAC which is protected from direct spray and leaking water, and which avoids contact to its back by loose gear and unsecured wires. Make a cutout in the panel or bulkhead about 1 1/4 " X 6 1/4" and fasten flush with #8 oval head screws and finishing washers.

WIRES

Number 16 or 18 stranded wire is ample to connect the AutoMAC to +12v minus/ground, and to alternator field. Heavier wire, for example #10 or #8 is recommended for the ammeter.

Wire to +12 Volt: connect to engine key switch or to some other source which is being switched off when the engine is shut down. This will avoid wasted field current if the AutoMAC is left on while the engine has been turned off. The AutoMAC cutoff circuit will respond to this source of +12 Volt. Wire to minus/ground: make a sound and solid connection which will carry several amps.

Wire to alternator field coil: use the Alternator Field section of this booklet to identify your alternator, and connect this field wire as outlined with that alternator.

After you have connected a wire to the alternator field, before connecting and using the AutoMAC, but with the ammeter connected and working, test the field wire: See "Test the Alternator Field Wire".

As a general guide, alternators of type P include Delco with separate external regulators, other brands with external regulators, Motorola to 55 Amp with external or attached regulators, alternators with DF terminal. Alternators of type N include Delco with internal regulators and "1", "2" terminals, Hitachi, Mitsubishi with internal regulators, Motorola of 75 Amp and higher. In all cases, the type MUST be verified by the text.

AMMETER FUNCTION

The ammeter will give an alternator output reading at all times the engine is running. The current shown on the meter is due either to the normal voltage regulator performance, or to the AutoMAC when that is in use. The ammeter should be connected and functioning before you test the new alternator field wire, and before the AutoMAC is first put in service. The ammeter will show a high surge of current immediately after starting the engine. This current will then taper off as batteries increase their voltage and the alternator warms up. Some current will continue to flow even after long hours of engine running since voltage regulator settings usually are about 14 Volt while batteries can only reach highest voltages which are below 14 Volt. With larger battery capacity and lower state of charge, the high current surge after starting will last longer. Also, with smaller alternators and lower alternator speeds, this surge, though lower, will last longer. In extreme cases, small alternators, running at low speeds, may hardly

ever reach the voltage setting of the voltage regulator and operate at their highest possible output for long periods of time. This condition exists if an increase in engine speed gives a proportional increase in alternator output current.

The voltage regulator begins to reduce its supply of field current after its voltage setting has been reached. Output current will then fall, but can be maintained at higher levels with the AutoMAC. The output level will then again be dependent on the alternator speed.

AMMETER WIRING

Note the sketches following. If your boat now has no ammeter, present alternator output wire is likely as in the upper left sketch.

WITH AMMETER NOW:

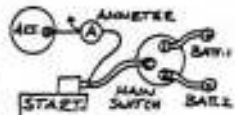

WIRE LIKE THIS:

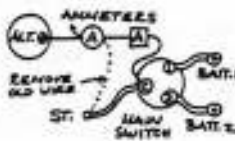

Remove this wire. Connect the new ammeter of the AutoMAC as in the sketch below, at the left. You may connect to the battery main switch instead of the starter solenoid. Old wire must be disconnected since it would short out the ammeter.

If your boat has an ammeter which now shows alternator output current, its wiring is likely that in the sketch at the upper right. Connect the new meter in series with the old meter. The alternator output current flows through one meter, then through the other, on the way to the battery.

If the present ammeter is a zero-at-center type, for example a minus 60 - 0 - plus sixty amp meter, one of its terminals will have two wires, one of them leading to the boat's electric panel. There are several ways in which the present and the new ammeters may be wired.

Meter readings may be different and will have different meanings. See the sketches. Meters show total alternator output current, or net

NO AMMETER NOW:

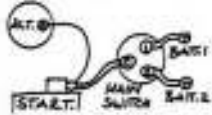

WIRE LIKE THIS:

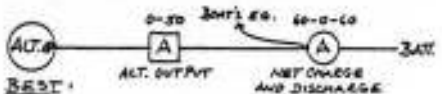
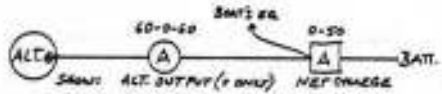
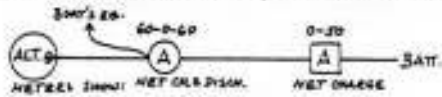
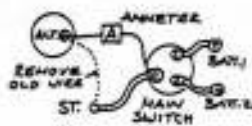

charging current (total output current minus current being drawn by other equipment at the same time) or, on center zero meter only, current being discharged from the battery while the engine is off.

Wires must be fitted with ring terminals which MUST BE SOLDERED. Wires for alternators rated to 40 ampere may be #10 AWG. For larger alternators, and for distances between alternator, ammeter and battery switch much over 15' should be #8 AWG, stranded. As soon as possible, test the wires under the highest load and check if any connections become warm. Repair or replace any such connections.

TEST THE ALTERNATOR FIELD WIRE

You must carry out a simple test to verify that this wire has been connected to the correct field terminal, to avoid damage to the AutoMAC. The test will also verify the alternator type, P or N.

Test with lamp (12 Volt light bulb, 10 Watt to 30 Watt). Connect the wires to the light bulb, for example, by soldering directly to its terminals. Keep the alternator field wire from accidentally touching any other terminals. The field wire is not yet connected to the AutoMAC. The AutoMAC remains switched off, but its ammeter is wired, another ammeter is in use, and the ammeter has been tested and is working.

Switch to one battery which may be the engine battery. Start the engine and note that the ammeter is showing relatively high current immediately after starting. Wait until this current surge has tapered off to less than 5 Ampere. While a helper is watching the ammeter, connect the field wire to the lamp (light bulb), and the other lamp terminal to ground or to plus 12 Volt, as shown in the sketch. It is not important whether the lamp glows or becomes fully bright. Important is whether the ammeter shows an increase from below 5 Ampere to well above 5 Ampere while the lamp is connected.

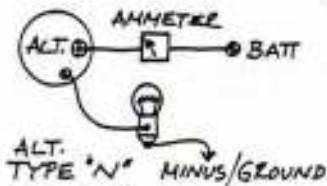
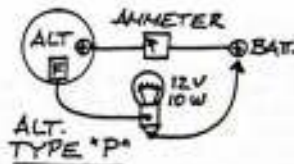

TEST RESULTS

Type P alternators

One wire is labelled F, FLD, F+, DF at the regulator or on the alternator. This is the field wire to which the new AutoMAC field wire has been connected. If in touching this field wire to the lamp to the plus 12 Volt (see sketch) gives an increase in ammeter reading, from less than 5 Ampere to 10 Ampere or more, depending on the engine speed and battery size, the field wire is correct. Proceed in connecting the AutoMAC while the engine and power are off. Follow the type P schematic.

For Motorola alternators to 55 amp with attached voltage regulators, see the Alternator File

section for details. Only a single green wire under the regulator is connected to one of two brushes. The other brush is connected to the minus or to the housing ground by its bracket. Test as in the first paragraph. If there is an increase in the ammeter reading, the field wire is correct and you have a type P alternator.

If you cannot get clear test results, or if the ammeter reading is slow to fall into the range below 5 Ampere, switch engine and then power off, disconnect the voltage regulator from the alternator, secure loose wires, but keep the field wire connected to the alternator field terminal and rerun the test. This time, the ammeter will read zero since there is no regulator field current. With the lamp connected as in the sketch, to the plus 12 Volt, a few Ampere should show on the ammeter. Wiring is correct, type P. Reconnect.

Type N alternators

For alternators with internal voltage regulators, Motorola alternators greater than 55 Amp with attached voltage regulators (two green wires to two brush terminals, no brush connected to minus/ground), the field wire for the AutoMAC is connected to the minus brush, or to the minus field terminal in brushless alternators (Delco, Nichoff).

Switch the battery and start the engine as outlined, with the field wire and lamp ready, AutoMAC off, and wait until the ammeter reading has fallen to 5 Ampere or less. Only then, connect as in the lower sketch. With the field wire to the lamp, other lamp wire to minus/ground, an increase close to 10 Ampere should occur, depending on the alternator speed and battery size.

Should the test not give conclusive results, continue to run the engine until the alternator output current (the ammeter reading) has fallen off further. The extra field current through the light bulb and its expected increase in output is likely being sensed by the voltage regulator which, at that moment, then reduces its field current so that no net change becomes visible. Also note possible test with the digital Ohm meter.

CAUTION: MECHANICAL OR RELAY TYPE REGULATOR

This electromechanical type of voltage regulator is now rare. It is not solid state and consists of one or more relay coils and moving contacts. It is always external and is usually connected as type P. You may use the AutoMAC with this alternator while this regulator is completely disconnected. ** See the Alternator File section on "Relay Type, Electromechanical Regulator" for special instructions.** Otherwise, this regulator will destroy the AutoMAC circuit.

TEST WITH DIGITAL OHM METER (Optional)

Such meters, including pocket digital VOMs, can tell the difference between a direct connection and connections through low Ohm resistance such as field coils and brush contacts. If such a meter is available, use it to verify correct field wire connections, see sketch, all with power off.

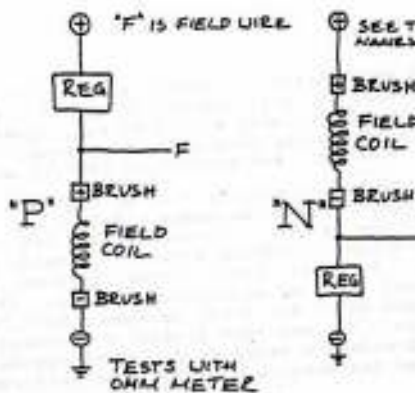

Type P alternator: Ohm reading between F wire and minus brush or ground should NOT be zero. Instead, with meter leads firmly attached, measure between F and minus/ground while rotating pulley. The readings should be higher than 4 Ohm, changing rapidly up and down as rotor is moved (with brush type alternators, changing resistance between brushes and slip rings).

Type N alternators: measure between excite, charge light, auxiliary plus, or diode trio terminal and F. Reading should NOT be zero, but should be 4 Ohm or higher, changing rapidly when rotor is moved (except with brushless alternators). F is same

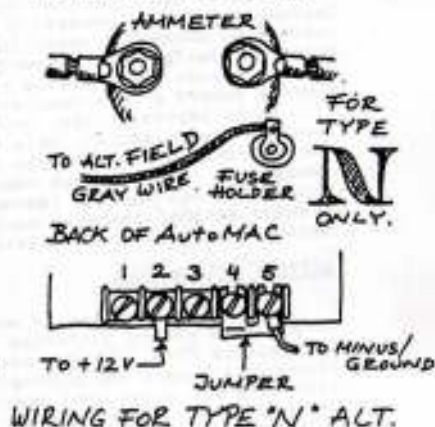
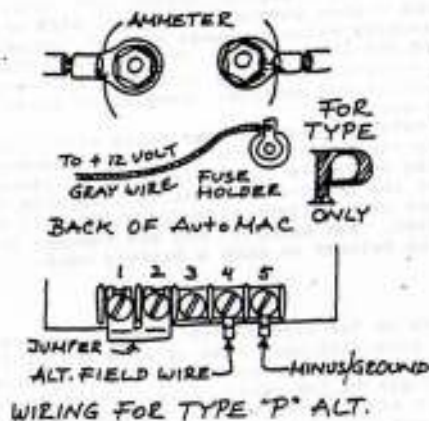

terminal as test hole terminal. On type N alternators, diode trio or light terminals are labelled "1" (Delco), "L" (Hitachi, Mitsubishi), "D+" or "61" (Bosch, Paris-Rhone, Marchal, or other European brands). Separate excite terminals may also be connected to plus brush but may have a 50 to 200 Ohm resistor in line.

OPERATION

The AutoMAC ammeter will show alternator output current from either voltage regulator or AutoMAC, that is, with AutoMAC on or off. Before starting the engine, switch the battery main switch to All unless there are charging diodes or splitter/isolating diodes in use. Avoid battery switching while the engine is running; see section on battery main switches.

Immediately after engine starting, current will be high but will fall off gradually as the battery voltage increases. Switch the AutoMAC on after the initial current surge is over. Gradually turn the black control knob from its "low" position clockwise until the ammeter shows the selected charging current. At first, limit current to about 2/3 of the alternator Ampere rating and feel the alternator housing. It is too hot if you cannot keep your hand on it for three seconds. CAUTION: watch the belt, fan and pulleys. You may then gradually increase to higher currents. Alternator brands are rated at different speeds and perform differently. Also read the section on alternator performance.

BATTERY CHARGING

Batteries can accept the greatest charging current when their state of charge is low. As they reach a more complete recharge, high charging current will cause excessive gassing which consumes some of the charging current to decompose water from the electrolyte. The AutoMAC automatic cutoff is designed to prevent excessive charging current: after cutoff, you can reduce the charging current and continue charging at lower current toward a more complete recharge.

It is important that you estimate your average daily electricity need in Ampere hours: this is the amount which you have to recharge to "break even" or to recharge the batteries to the level after yesterday's charging. If you cannot reach the break-even point in less than two hours, you can usually increase your battery capacity which will allow greater AutoMAC charging current. For example, you may connect another battery parallel to an existing battery to make a battery bank.

BATTERY MAINTENANCE

Use distilled water to make up the electrolyte level in the cells. If you have sealed batteries, note that only some of them are truly maintenance free. These have a catalyst in each cell which chemically recombines oxygen and hydrogen gas to form water again. Other sealed batteries may carry just enough electrolyte to last through their warranty period when used in cars (where batteries are fully charged most of the time). With this kind of sealed battery on the boat, find the vent holes which may be hidden under a label and use a syringe to replenish the electrolyte with distilled water.

EQUALIZING CHARGE

The cells and plates in a battery, and batteries connected in parallel, are never exactly alike. They can develop differences in their state of charge which can gradually increase. Cells or plates which are lower than the rest then come closer to complete discharge

when the battery becomes nearly empty. To allow such cells to catch up, an equalizing charge is used. After most cells have reached full charge, a modest charging current (about 2 to 5 Ampere for 100 Ampere hours of capacity) is continued for several hours. This current allows lower cells or plates to reach full charge while it overcharges the others. Check and add water. An equalizing charge once or twice each season is probably ample.

THE AUTOMATIC CUTOFF

During final testing, the cutoff voltage setting has been adjusted to a value between 14.6 and 14.8 Volt. The actual setting for your unit is marked on the outside of the box. ANY ADJUSTMENTS OR ALTERATIONS TO THE FACTORY SET VOLTAGE CUTOFF VOIDS THIS UNITS' WARRANTY.

Battery voltage will gradually climb as charging current is flowing through the battery. During battery charging with the AutoMAC, when the battery voltage reaches the predetermined cutoff point, the automatic cutoff circuit will be triggered. This circuit will then turn on the RED LIGHT to tell you that the cutoff point has been reached. It will also switch off all field current which you had selected by the black knob. THE RED LIGHT WILL REMAIN ON, and the AutoMAC will remain cut off, until all power to the AutoMAC has been disconnected (if the engine is being shut down), or until the black knob setting is turned counterclockwise down, and the small RESET BUTTON pressed for a few seconds. You may continue charging the battery at a lower rate by turning the black knob clockwise again. At this lower current, some time will pass until the cutoff voltage will again be reached and the AutoMAC will cut itself off again.

RESET BUTTON

The small red reset button momentarily interrupts the voltage signal to the outoff circuit. Resetting will only be effective if the alternator charging current has first been reduced, by turning down the black knob and reducing the ammeter reading. This will reduce the alternator output voltage and battery voltage to a value below the AutoMAC outoff voltage setting (which is 14.8 Volt). The outoff circuit will be released if you now press the reset button. Battery charging with the AutoMAC may continue, but must be at settings which keep the battery voltage below the outoff voltage.

NOTICE: TECHNICAL CONSIDERATIONS RELATED TO THE PERFORMANCE OF ALTERNATORS WITH THE AUTOMAC

1. ALTERNATOR SPECIFICATIONS: Alternator nameplate ratings for output current (for example 35 Amp, 55 Amp, or 90 Amp) apply at a specified alternator speed and load. Almost all alternators on marine engines are operated at speeds far below the rated speed, while loads, in form of the boat's batteries, are usually large. Both have an effect on the alternator performance.

2. ALTERNATOR SPEED: With the engine speed known by a tachometer, the alternator speed is determined by pulley ratio: diameter of engine pulley divided by diameter of the alternator pulley. Example: 8 inch engine pulley and 3 inch alternator pulley give a pulley ratio of 2. Engine speed of 2000 X 2 = 4000 RPM.

3. ALTERNATOR AMP OUTPUT: The maximum alternator output current on your boat, with your batteries, and at an engine speed which you select, may be determined as follows:

Select the engine speed. Observe your ammeter reading. The meter must be wired to show the total alternator output. While noting the ammeter reading, in steps, switch on the cabin lights, deck lights, and other electrical loads until the ammeter reading does not increase any further. This reading, then, is the maximum alternator output current for that engine speed and alternator RPM.

This alternator amp output varies for different engine speeds. You may wish to run this test at different engine speeds to see the various results.

4. PERFORMANCE OF ALTERNATOR CONTROLS: AT NO TIME WILL YOUR ALTERNATOR CONTROL (AUTOMAC OR OTHER SPA CREEK CONTROL) BE ABLE TO INCREASE YOUR ALTERNATOR OUTPUT BEYOND THE MAXIMUM OUTPUT FOR THAT RPM. The AutoMAC can bring the alternator output back to maximum output, see above, after the voltage regulator has begun to reduce alternator field current, in order to keep the alternator output voltage at the setting of the regulator.

5. VOLTAGE REGULATOR SETTING: To determine the voltage regulator setting of your alternator, use an accurate voltmeter or VOM and measure between the alternator output terminal and ground, battery plus and minus posts, or circuit breakers feed bus and ground. Take this reading after the engine has been running long enough so that the ammeter reading is a small fraction of the maximum output amps and the reading does not increase with increased engine speed. Voltage regulator settings range from about 13.8 to 14.4 V.

6. STAGES DURING THE ALTERNATOR OPERATION: After starting the engine, the batteries will keep the alternator output voltage below the voltage regulator setting. This will cause the alternator to produce maximum output. Its magnitude will determine how long such current has to flow until the battery voltage reaches the voltage regulator voltage setting. During this time, the alternator is at full output for its given speed. Any increase in speed will produce an increase in output current. External controls, such as the AutoMAC, cannot increase output during this stage since it is already being held at its maximum by the voltage regulator. Turning the controls up or down will have no effect.

At the time when the alternator charging current is able to raise the battery voltage to the regulator voltage setting, (when the battery voltage WITH CHARGING CURRENT FLOWING reaches 14.0 V or the value of your alternator - see previous section) the voltage regulator will begin to reduce the field current just enough to maintain 14.0 V at the alternator output terminal. Since batteries continue to take on charge, the voltage difference between 14.0 V at the alternator, and the voltage of batteries (standby voltage, if no current were flowing) gets smaller with time. This voltage difference is the one which causes charging current to flow, and the charging current, therefore, also keeps falling.

During this stage, when the voltage regulator controlled output keeps falling, the AutoMAC will be able to increase the alternator output back to maximum output. That output, again, will greatly depend on the alternator speed. The batteries now show a gradually increasing voltage, as their state of charge increases, and the alternator will have to produce greater power (wattage) to generate a given charging current than earlier, when the batteries were more nearly discharged. 30 Ampere charged into the batteries at 13.0V = 390 Watts. Later, 30 Ampere at 14.5V = 435 Watts. If the alternator had been at maximum output all along, it will, in this example, only produce about 27 Ampere (390 Watts).

7. VARIABLES WHICH AFFECT THE ALTERNATOR OUTPUT CURRENT:

- A) Alternator nameplate ratings (the alternator "size")
- B) Battery capacity: bigger batteries make high initial current fall back more slowly.
- C) Alternator speed: no practical upper limit (10,000 RPM ok)
- D) AutoMAC setting: see earlier details
- E) Voltage regulator setting, after that setting was reached.

ISOLATING OR CHARGING DIODES, SPLITTERS

Charging diodes, by any of these names, have an input terminal which is connected to the alternator, and output terminals which are connected to the plus terminals of each battery or each bank of batteries. With the AutoMAC, the wiring is as follows: Wire the alternator plus output terminal with heavy wire to plus terminal of ammeter. Use the same heavy wire from the minus terminal of the ammeter to the input terminal or common terminal of the charging diodes or splitter. Then from each charging diode output terminal to the corresponding battery plus terminal.

BATTERY MAIN SWITCHES WITH FIELD DISCONNECT

The alternator field wire used with the AutoMAC cannot be used for the field disconnect feature because, with the AutoMAC interrupted, the field terminal from the voltage regulator will still be flowing. In alternators with external voltage regulator, the field disconnect switch is wired between alternator F terminal on one side, and regulator - and - AutoMAC on the other (type P). On alternators with internal voltage regulator (usually type N), the field disconnect switch must be wired between diode trio and plus brush. This can often be done while a field

wire is installed for the AutoMAC.

CAUTION: Such battery switches disconnect filed current only while being switched to off position. Risk of disconnecting the running alternator from the batteries still exists when the copper contacts in an older battery switch have become tarnished or even slightly corroded. We strongly recommend that you SWITCH TO "ALL" BEFORE STARTING THE ENGINE, SWITCH TO THE SELECTED BATTERY AFTER THE ENGINE IS OFF.

ISOLATED GROUND ALTERNATORS

Alternators of this type have the minus output terminal isolated from the alternator housing. Such alternators MUST have a minus wire connected between their minus terminal and battery minus (isolated ground system) or engine ground (isolated minus feature not used). This wire carries the same amount of current as the plus output wire and must be of the same size. Disconnecting this wire while the engine is running disconnects the alternator from the battery load and causes damage. Alternators in this group are Hitachi with isolated E terminal (plastic washer visible) and Paris-Rhone with isolated D-terminal. This feature is more common in larger alternators.

HOW TO TEST THE AUTOMAC

Disconnect all wires and the jumper wire from the AutoMAC terminals. Now connect the gray wire (on the fuse holder) to the plus 12 Volt and terminal "5" to the minus/ground. The sketch shows the terminals at the back of the AutoMAC. Connect the test light between "4" and "5" as in the sketch. Then turn the AutoMAC toggle switch on and control knob up and down. As you turn the knob, the test light should become bright and dim. THIS IS CORRECT. If the test light remains dark, use it to test the source of plus 12 Volt. Test the light wires to the base of the fuse and separate reliable ground. If bright, OK. Test the ground: light to the base of the fuse and to terminal "5". If bright, OK. Test the fuse: test light wires to "5" and to "1". If bright, fuse is OK.

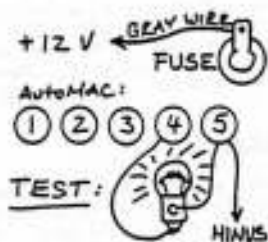

TROUBLE SHOOTING GUIDE

Following are some problems and cause/solutions:

PROBLEM	CAUSE/SOLUTION
Ammeter not reading correctly	1.) Check the connections. They must be soldered, not crimped.
Low output	2.) Must be wired first in series with any other ammeters, there should only be one wire from the alternator battery terminal to the AutoMAC ammeter. 3.) Review the ammeter wiring section of this book. 4.) Check the engine RPM.
Red LED lights too soon	1.) Check the 12 Volt source with VOM (multi-meter) for possible "noise" or voltage spikes.
No output control, Red light off	1.) Recheck the field wire test. 2.) Test AutoMAC - review previous section.
Fuse keeps blowing	1.) Incorrect field wire connection.

ALTERNATOR FILE

PURPOSE

The Alternator File gives details for specific brands and models of alternators and points out where to connect the field wire needed for the AutoMac, T-Mac and other Spa Creek alternator controls.

ALTERNATOR TYPE

Listed with the alternator sketches is the alternator type, either N or P, which you should note and mark in your manual. Alternator types P (Positive) and N (Negative) are our own designation and do not relate to any letters on the alternator labels. Note the test which determines or verifies the type of your alternator.

THE FIELD WIRE

Only this one wire is needed between your alternator and any of the Spa Creek alternator controls. The letter "F" and an arrow is used in the sketches to point to the terminal or contact where this new field wire is connected. Any other wires will remain connected as before. Use number 18 or 16 AWG stranded copper wire with vinyl insulation.

FIELD WIRE SERVICE

If you prefer, we will connect the field wire to your alternator. Package tightly, attach label with your name and street address. Enclose a check for \$35.00 U.S. funds. We will connect the wire, mark the alternator type, and ship back promptly by UPS.

TURN POWER OFF

Before you start, turn off all power to the alternator, engine and starter. If you take the alternator off, label all wires and tape their ends to prevent accidental contacts.

SIMPLE: ALTERNATORS WITH EXTERNAL REGULATOR

Several such alternators are shown in the sketches. Look for the separate voltage regulator which often is a small metal box with one or more wires to the alternator. Then inspect the alternator and connect the new field wire to the terminal F, DF or FIELD which will have a wire connected to the voltage regulator; leave this wire connected. Then inspect the regulator more closely.

RELAY TYPE, ELECTROMECHANICAL REGULATOR?

If your regulator has coils and contacts and is electromechanical

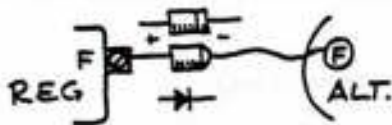

instead of solid state, it needs a blocking diode at its F terminal. See Sketch. The diode (Type "1N5404") lets the regulator current flow only in one direction. Note the plus and minus signs, diode symbol, and diode appearance, pointed or with a band marking one end.

REGULATORS ATTACHED TO THE ALTERNATOR

These alternators will not have a field terminal on their outside, but connecting the new field wire is still simple. In the sketches, find your alternator by comparing shape and appearance, label, if any, locations of terminals. Even though the field terminal is not obvious, note that you do not have to open the alternator, but instead, only expose the field terminal under the attached voltage regulator. Follow the details with the sketch. Test the field wire. Attached regulators are always solid state types. Alternator may be type P or N.

INTERNAL REGULATOR

Alternators with internal voltage regulators usually must be opened to connect the new field wire. Be aware that the normal alternator shops will not be familiar with our alternator controls and will not likely read the instructions.

THROUGH BOLTS

There are either three or four long thin steel bolts which hold the alternator housing together. Before you take them out, mark front and back of the housing, as there will be three or four ways the parts will fit together when you reassemble.

SEPARATING FRONT AND BACK

Always separate the front half of the alternator housing with pulley and rotor from the stator which must remain with the back half of the housing. Stator is made from laminated sheet steel and easy to recognize. See Sketch. To pry them apart, use a flat screwdriver in the slots at opposite sides, or lightly tap the front housing.



THE BRUSHES

Looking down into the back housing, you will see the two brushes. We will call one the upper, inner brush and the other the lower, outer brush. As you view them, they are upper or lower brush. They are also inner brush close to the center, or outer brush away from the center of the alternator. In essence, the new filed wire will always be connected to one or the other brush.



BRUSHES: READ BEFORE YOU REASSEMBLE

You cannot assemble the alternator until after you have pinned the brushes out of the way. All alternators have small holes in the brush holder and back housing for a wire to hold the brushes back. Start from the inside, push the upper brush back, insert the wire (paper clip), then push back the lower brush. Advance the wire until it extends out of the back housing. Leave just enough wire inside to hold back both brushes. Install the through bolts, then pull the wire out to release the brushes. (DO NOT FORGET!)



FIELD WIRE TEST

Use this test to check field wire and alternator type before you connect the alternator control. This test requires a 12 Volt light bulb of about 10 Watts. As sketched, connect one lamp terminal to the new field wire, start the engine, watch the ammeter while you touch the other lamp terminal to plus or minus. Note any ammeter changes and mark the box which has your results.

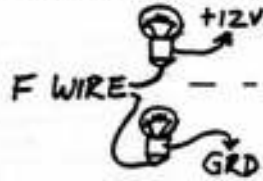

Lamp dark Ammeter no change or down	Lamp dark Ammeter no change
Lamp glows Ammeter Up	Lamp bright Ammeter no change
OK, type N	WRONG

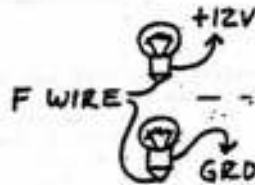

Lamp glows Ammeter Up	Lamp bright Ammeter no change
Lamp glows Ammeter down	Lamp dark Ammeter no change
OK, type P	WRONG

Wrong connection most often will have the field wire on the wrong brush.

UNKNOWN ALTERNATOR IDENTIFICATION: TYPE P, TYPE N, FIELD

These tests allow unknown alternators to be used with SpaCreek Alternator Controls. Make notes of the test results.

1. Inspect the outside of the alternator for terminal(s) marked F, FIELD, or DF and mark with the letter A (and B, if two). Proceed with test 4.
2. If there isn't an external field terminal(s), open the alternator by removing three or four long thin screws, gently prying the front half of the housing (with pulley and rotor) from the back half of the housing (with stator and its wire coils). Inside this back housing, look for the two carbon brushes which are normally in contact with two copper "slip rings" on the rotor shaft. Brushes are on spring loaded arms or in holders similar to SKETCH 1. Each brush has a soft wire connection to a

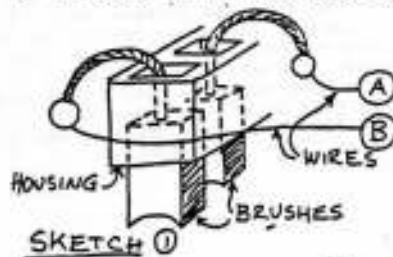

metal connector nearby. Look for it, or use Ohm meter. Then measure if one of the brushes is connected directly to ground/minus; minus brush in a Type P alternator. Otherwise, connect a thin, well insulated wire to each brush as sketched and call them A and B, lead to outside and secure against chafing. REASSEMBLE the alternator using a stiff wire and a paper clip to hold the brushes back. The wire is to extend out through the alternator housing through a hold for that purpose. Put the rotor and alternator halves back together, install the screw and tighten evenly, then firmly. Pull out the wire to release the brushes. Reinstall the alternator while the batteries are disconnected, connect all old wires.

3. TEST: TYPE P OR TYPE N -



Use a Volt Ohm Meter (VOM) as in SKETCH 2. Switch to V DC range and measure wires A and B versus ground or alternator housing. Do not short the wires, do not touch to ground or other terminals. Wires A and B may be as long as you need them. Test while the alternator is running and the ammeter shows some (any) output.

TEST AND MARK:

A	+5 to +15V	A	+5 to +15V	A	zero V
B	+5 to +15V	B	zero V	B	+5 to +15V
ALTERNATOR IS:	TYPE N		TYPE P		TYPE P
FIELD TERMINAL:	Use Test 4		Use wire A		Use wire B

Of wires A and B, only one is needed. Cut, insulate, secure, or remove the other which, in the case of a Type N alternator, will carry positive voltage.

4. IDENTIFY FIELD TERMINAL:



Use a test light as in SKETCH 3, or make from a 12 V lamp, as shown, by soldering wires directly to the lamp base. Use a lamp of about 10 Watts. Connect one wire X to minus/ground, and have a helper watch the ammeter (engine panel). Touch the other wire to A, then to B. Only in one case will the ammeter reading go up (lamp may or may not light). Use that wire as the field terminal.

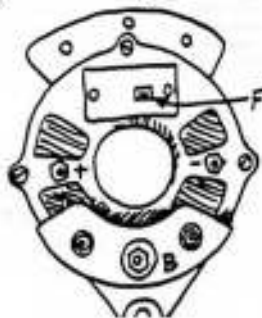

MOTOROLA (116)

External regulator, Type P

Connect new field wire to F, leave present wire connected. Check for relay type electromechanical regulator, install blocking diode if applicable.

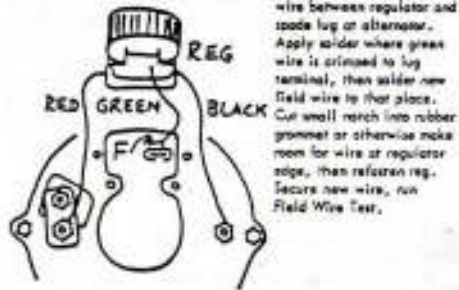
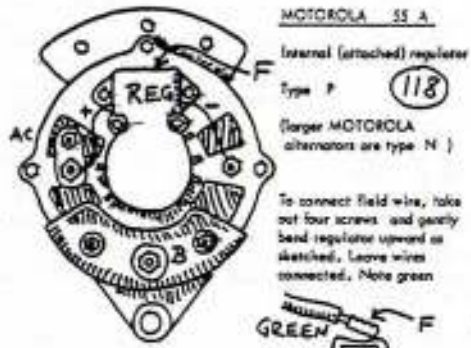
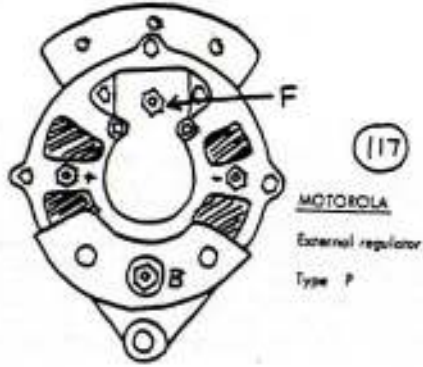

MOTOROLA

(119)



Internal (attached) voltage regulator on alternators larger than 55 A. Type W. Note two spade lug terminals at the top of the regulator housing. Lower sketch shows two green wires under the regulator. To connect the field wire, apply solder to the wire crimp at F, then solder the new wire to that same place, lead to the outside. Refasten regulator. Check with Field Wire Test.

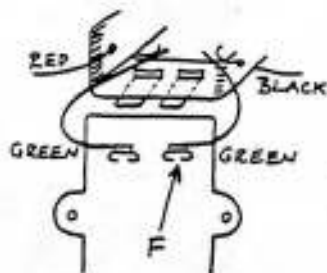

MOTOROLA

(122)



"Flush Back" Internal (attached) voltage regulator. Type P.

The SKETCH shows the solid state regulator which is mounted in its matching recess. Its outer surface is flush with flat back of the alternator.

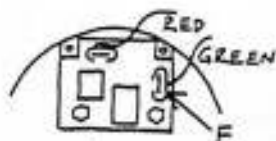

To connect the field wire, remove the screws which hold the regulator. Fold regulator back as much as the wires allow and note the wires under the regulator. As sketched below, a green wire is fastened to push-on spade terminal F. Another red wire connects the regulator to the alternator. Apply some solder where arrow F points to the crimped end of the green wire. Solder new field wire to that same place. BE CAREFUL when you fasten the regulator again. Make a small notch to avoid mashing the field wire insulation.

MOTOROLA (123)

Internal (attached) voltage regulator, Type P.

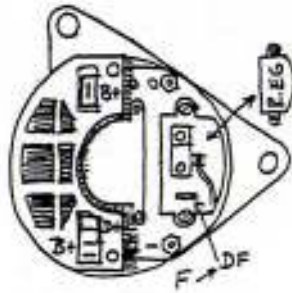

SKETCH shows regulator removed. To connect the field wire, take out the screws which hold the regulator. Gently pry up the regulator itself. Souse, or all, connections between the alternator and regulator are by spade or other metal contacts which should not be bent. Note "DF", which marks the field terminal. Clean a small area at the base of the lug. apply a small amount of solder. Solder the end of the new field wire to that place. Make a small notch at the edge to run the wire to the outside. Bring the regulator back into position evenly so contacts engage. Reattach. Run Field Wire Test.

MOTOROLA ALTERNATOR ON UNIVERSAL DIESEL ENGINE

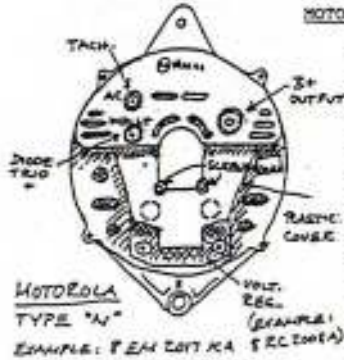

Alternators with the appearance of back housing as in the sketch, have a large plastic cover over the back housing. Remove the wires from the terminals. Also remove the terminal nuts and washers from AC/Tach, Ind. Light, and output terminals. Remove two small hex head screws near the center and pull off the plastic cover. Save the felt gasket which seals the brush compartment. NOTE THE DETAIL SKETCH. Each brush has a braided wire to a metal conductor with stud and hex nut terminal at sides of brush holder. Prepare a field wire from stranded #14, 16 or 18 insulated wire with a solder ring terminal. Connect this wire to the brush terminal at the right in SKETCH, marked with arrow "F". Lead the wire to have it exit to the right. Reinstall the cover and felt gasket. Fasten with two screws, nuts and washers at terminals. Label the FIELD WIRE TYPE N and connect to AUTOMAC as in Type N Wiring Sketch. Test the ammeter, which should give amp readings at all times the engine is running.

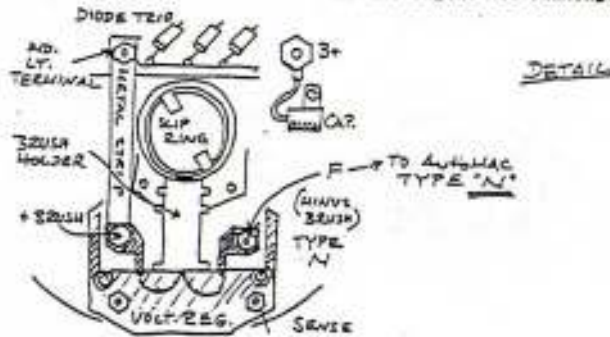

HITACHI LR-135-31 35 A (231)

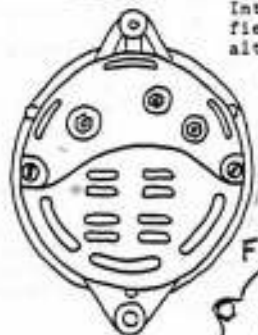

Internal regulator - Type N (on Yanmar) To connect the field wire, switch off power, label wires and take off the alternator. Remove the plastic cover from the back of the alternator. Under the cover, note the solid state regulator, second SKETCH, which has a wire connected to spade lug in rectangular hole, see F. Pull this (white) wire, with connector off and out away some of the soft plastic insulation. Apply some solder and solder the new field wire next to the existing wire to the connector. Push connector (now with two wires) back on to the spade terminal. Secure the new wire and run through one of the slots in the plastic cover. Refasten cover



HITACHI LR 135 - 55 A



Internal Regulator, Type N (232)
(As on Yanmar)

To connect field wire, take off wires while main switch is off. LABEL. Remove plastic cover from the back of the alternator. Under the cover (second SKETCH) note the white wire from the regulator connected to spade lug, recessed within rectangular hole, marked F in the sketch. Pull wire with connector off, clear some of the soft plastic insulation and solder the end of the new field wire to the connector. Push the connector with new and old wire back on to the recessed spade terminal. Lead the new wire through one of the slots in the plastic cover. Secure. Fasten cover. Test new field wire with Field Wire Test.

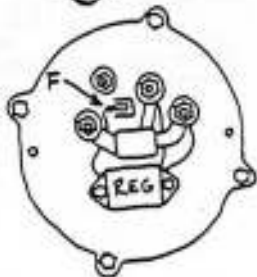

detail

HITACHI LR 135 - 74

35 Ampere Internal regulator Type N (233)

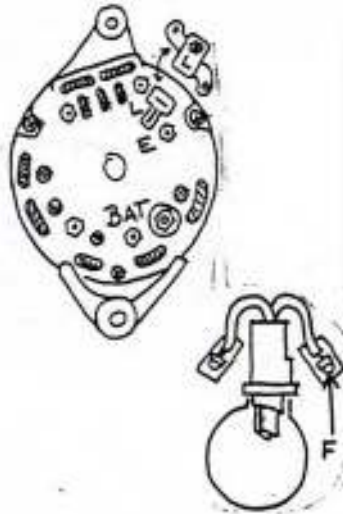

To connect field wire, remove three through bolts, separate front housing with pulley from back housing with stator. In back housing, note brush holder and wires to brushes. See detailed SKETCH. The upper, inner brush has its wire connected on the left. The lower, outer brush has its wire soldered to a small post on the right. Add the new filed wire here. Tin the end of the wire first, then solder on. New and old wire must remain soldered. Lead new wire to outside, secure. Read instructions about brushes before you reassemble. Field Wire Test.

HITACHI 50 A / 50 A (235)

Internal regulator, Type N

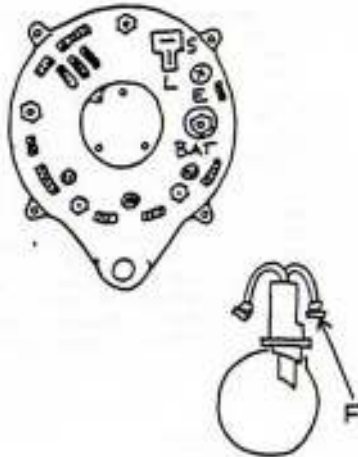

To connect field wire, remove four through bolts, separate from housing with pulley from back housing and stator. At bottom of back housing, note brush holder with brush wires extending out as in the detailed sketch. Wire from lower, outer brush turns right to soldered joint. First apply solder to the end of the new field wire, then solder to the joint, leaving existing wire connected, both at "F". Run the wire to outside through vent hole. Secure. See instructions for brushes before you reassemble.

DELCO - REMY DELCOTRON To 63 A (325) External regulator, Type P



Important: note two spade lugs which are parallel to each other, not in line as on some other Delco-Remy alternators. Lugs are shown in detail and marked R and F in sketch. Connect new field wire to the wire now on lug F. If remote external regulator is relay type, with coil and contacts in metal box, connect blocking diode. See details in the manual. If no other regulator is being used, field wire can be soldered directly to F lug on alternator. Bend lug to center slightly, place the end of the wire through the hole in the lug, solder. Straighten lug and slip a length of spaghetti tubing over it to insulate against alternator housing.

DELCO - REMY DELCOTRON to 63 A (326) Internal regulator, Type N

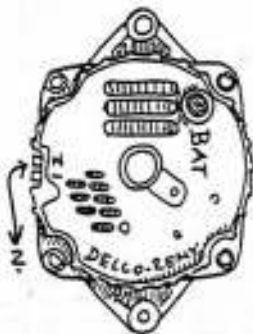

Important: Note two or three spade terminals, shown in the sketch at left, marked "1" "2". Make certain that spade lugs are "in line", as in the detail sketch, not side by side. There may be an "R" terminal also. To connect the field wire, take out four through bolts, separate front and pulley from back housing and stator. Note plastic regulator (with "1" and "2" lugs extending out side), held by hex head screws. Take screw marked F out, together with its plastic insulating sleeve. Connect the new field wire, with ring terminal, under screw. Refasten screw with insulator, run wire through vent hole to outside, secure. Read instructions about brushes before you reassemble the alternator. Run the Field Wire Test.

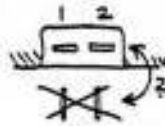

BOSCH 35 A (404) External Voltage Regulator: mechanical or solid state. Type P



BOSCH 35A F

Note terminals D+, D-, W: you will have wires connected between alternator and remote regulator. All will remain connected. Add a field wire to alternator terminal DF. Use a ring terminal at the end of the new wire. Take a close look at the regulator. Read about the blocking diode with electro-mechanical or relay type regulators and install, if applicable.

BOSCH Q1 33 Ampere External regulator, Type P (405)

Connect field wire at "F", check for relay regulator and install blocking diode if applicable.

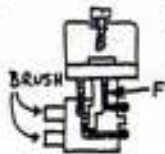
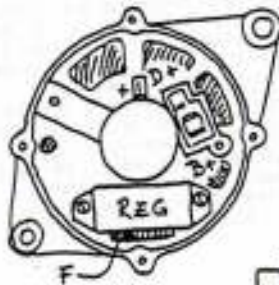

BOSCH K1 55 Ampere External regulator, Type P

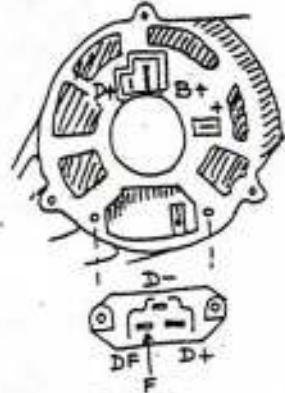

BOSCH K1 55 Ampere Internal (attached) solid state regulator with brush holder. Type N 5" dia. (406)
Note the similarity to 65 A model. To connect the field wire, remove two screws while holding the regulator in place. Angle upward and lift out. Solder the end of the field wire to the flat metal conductor of the upper brush, "F" in detail sketch. Hold the brush in, if you have to heat the brush wire soldered joint nearby. Reinstall brush holder/regulator, secure wire.

BOSCH 65 AMPERE Internal (attached) regulator with brush holder. Type N (407) Similar to other 65 A and 55 A alternators. To connect the field wire, remove two screws while holding the regulator in place, then angle upward and remove regulator. Look at it from the side (lower sketch). Solder the field wire to flat metal conductor to the upper, outer brush. Hold the brush in, if you have to heat its solder joint (brush spring tension). Reinstall brush holder, evenly, to have it contact the flat metal tongue squarely, which touches the metal conductor to the other lower, inner brush.

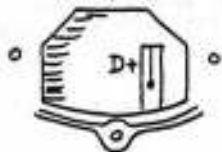
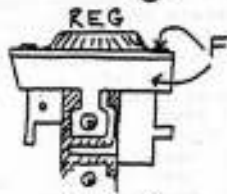
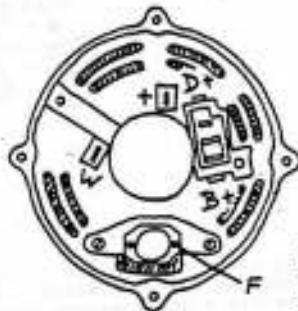
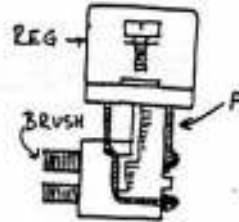

BOSCH 65 AMPERE Internal (attached) regulator with brush holder. Type N (408) To connect the field wire, remove the plastic cap from the solid state regulator and note its two fasteners. If they are brass, clean and solder the field wire hear. Use a hot solder iron, quickly, tin fastener and wire separately first. If hard to solder, remove two screws and regulator assembly. Solder to side at "F" in sketch. Note the spring contact "D+" which must make contact squarely when you reassemble. Secure the new wire and test with Field Wire Test.

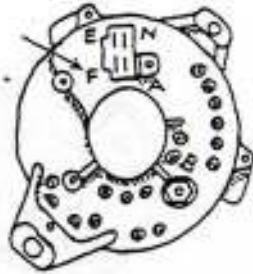

MITSUBISHI 35 AMPERE External regulator
 Type P 4 1/2" diameter (551)
 Connect the new field wire to the wire now
 on terminal F so that both new and old wire
 make contact to spade lug F. Check for
 relay type, electromechanical regulator,
 install blocking diode, if applicable.

MITSUBISHI 50 AMPERE External regulator
 Type P 5" diameter (552)

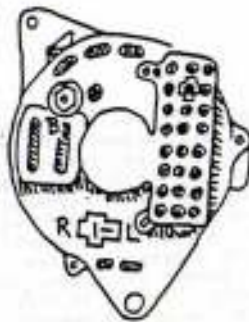
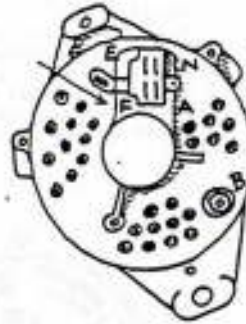

MITSUBISHI 45 A Internal solid state
 regulator. Type N 4 1/2" diameter. (553)
 To connect the field wire, remove three
 through bolts, separate front housing with
 pulley from stator and back housing. At
 the bottom, inside the back housing, note
 the brush holder. On its left, as
 sketched, a flat metal conductor runs to
 the flat round bolt head. Solder the new
 field wire to "F", right of plastic
 insulator (dotted in sketch). Run to the
 outside through the vent. Secure. Read
 the instructions for brushes before
 reassembly. Test with Field Wire Test.

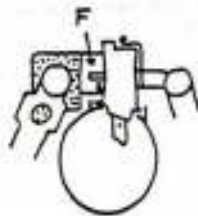

MITSUBISHI 56 A Internal solid state regulator. Type N. 5 1/4" dia. (556)
 To connect the field wire, remove the three through bolts, separate the front housing with pulley from back housing and stator. Locking into the back housing, note the brush holder (see sketch) with a flat metal conductor, round bolt head, clear plastic insulator marked here with dots. Solder the new field wire to the place marked "F" on the flat metal at the left of the brush holder. Run the wire through the vent hole to the outside and secure. Before re-assembly of the alternator, see instructions on brushes. Test with Field Wire Test.

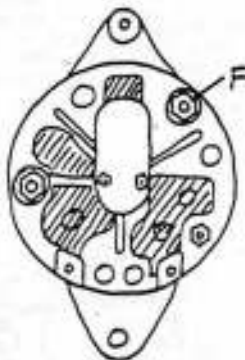
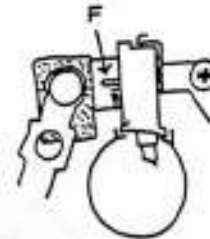
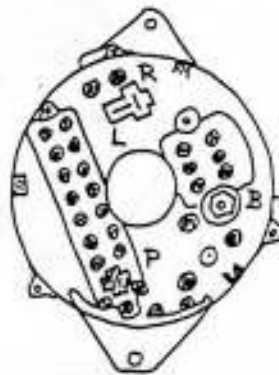

PRESOLITE External regulator, Type P (601)
 The oval at the center of the sketch is a cover which extends about one inch from the back of the alternator and covers the brushes. This alternator is in use on marine engines. Connect the new field wire to the field terminal "F" at the back of the alternator, in addition to the present wire which runs to the voltage regulator. If the regulator is relay type, electromechanical, with coil and contact, install the blocking diode at the regulator.



AUTOLITE FORD External regulator, Type P (622)

Connect the field wire to FLD field terminal. Check for mechanical or relay type regulator and install blocking diode, if applicable.

MOTORCRAFT FORD 60 AMPERE regulator, Type P (623)

External

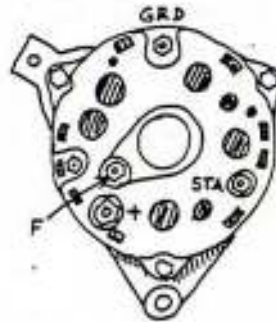

NIPPONDENSO External regulator, Type P (711)

Check for relay type regulator. Connect field wire to "F". To leave the existing wire now on "F" in place connect to the wire now on "F", near the plug. Make a 3-wire splice (to alternator "F", to new field wire, and to old wire from the external regulator) and insulate.

HITACHI 50 A External Regulator, Type P (236)

Check for relay type regulator.



NIPPONDENSO Internal regulator, Type N
(718)

To connect the field wire, remove three through bolts, separate the front housing with pulley from stator with back housing. At the inside back housing note the brush holder, see sketch. Solder the new field wire to the edge of the metal conductor marked "F", which is in contact with the upper, inner brush. Solder the wire to the outside and secure. Read the special instructions about brushes before reassembly of the alternator. Test with Field Wire Test.

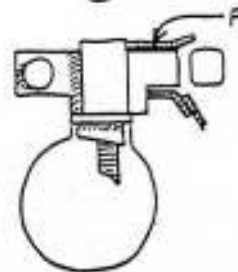

NIPPONDENSO Internal solid state regulator
Type N (714)

To connect the field wire, remove three through bolts, separate front housing with pulley and rotor from the back housing with stator. Note the brush holder. Outer, lower brush as you look into the back housing is connected to aux. diodes and is the plus brush. Inner, upper brush is the minus brush. Connect the field wire to the minus brush by soldering to the edge of the metal at the top of the plastic brush holder. See Sketch. Run wire out through the vent hole and secure. Read the instructions about brushes before you reassemble the alternator.

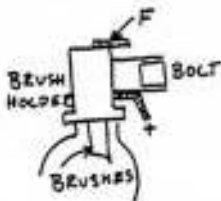

LIMITED NEW PRODUCT WARRANTY

Your new instrument is warranted against defects in material and workmanship for one (1) year from the date of original purchase. In the event of any such defect, return the instrument, postage prepaid, along with proof of purchase and an explanation of the defect to the address set for above. It will be repaired or replaced at our option and our expense. Any defect caused by misuse, accident, tampering or negligence of the user is not covered by this warranty. Be certain to carefully and securely pack the instrument for return, since we will not be responsible for damage in shipment. The repaired or replacement instrument will be returned to you, postage prepaid.

All implied warranties covering merchantability, fitness for a particular purpose, or otherwise, are limited in duration to one (1) year from the date of original purchase. The repair or replacement of any defect is the exclusive remedy under this warranty. In addition, the warrantor shall not, under any circumstances, be liable or responsible hereunder for consequential, incidental, or special damages. Note that some states do not allow limitations of incidental or consequential damages, so the foregoing limitation or exclusion may not apply to you. This warranty gives you specific legal rights, and you may also have rights which vary from state to state.

NOTE: Package carefully, as C.Plath cannot be responsible for damage in transit. Be sure to include a note describing the problem, your phone number, mailing address, and proof of purchase if claiming warranty. All inquiries, returns under warranty, etc. should be directed to:

C. PLATH
NORTH AMERICAN DIVISION
222 SEVERN AVENUE
ANNAPOLIS, MD 21403
(301)263-6700