

**SHERWOOD®**

# Maintenance & Repair Manual

*Your Complete Guide to Rubber Impeller Pump Identification & Repairs*



# The First 100 Years

**T**he seawater pump is the heart of the marine engine, supplying a continuous flow of raw water to maintain temperatures consistent with the demanding engine performance. Over the years, Sherwood seawater pumps have developed a reputation of excellence in quality; and today are chosen for their performance and dependability by the most prestigious marine engine manufacturers.

In the beginning, dating back to 1903, William Sherwood and his friend and business partner David Buick (of General Motors fame) operated a copper brass plumbing business. They parted ways as Buick became more interested in the automobile. Sherwood then developed the plumbing accessories and beer equipment business into a foundry and machine shop, as Sherwood was sought out by Ford, the Dodge brothers, and others for the expanding auto-driven industries in Detroit, Michigan.

In the 1920s, Chris Smith helped create the inboard-powered pleasure boat industry by combining automobile engines and boat hulls to increase speed with greater detail, style and comfort. His company (Chris-Craft) incorporated William Sherwood's expertise of plumbing and custom manufacturing as they developed the first seawater pumps for marine inboard engines.

The commitment in the marine field continued with the next generation of Sherwood. World War II furthered this commitment, as Sherwood became a prime supplier of Marine Engine Coolant Pumps for the United States Navy. On June 6th, 1944, a Chris-Craft built personnel carrier with a Sherwood pump was the first allied Landing Craft to hit the Normandy beaches. During this time, Sherwood also supplied pumps to marine engines of Buda, Caterpillar, Cummins, Gray, Hercules and Packard.

With the advance of pleasure boating after WWII, activities were turned to accommodating the exacting cooling pump needs of this growing market. Sherwood kept pace with the new engines from GM, Chrysler and Ford by continuing, expanding and developing relationships with Chris-Craft, Chrysler Marine, Crusader, Escort Marine, OMC and Pleasurecraft Marine.

In the 1970s, Sherwood joined Hypro and continued its focus on pump and pump-related manufacturing. Today, the Sherwood brand has taken the history of quality designs and manufacturing to become the seawater pump of choice for new marine Diesel and Gasoline engines. Sherwood services customers throughout the world with the help of the marine industry's leading engine manufacturers, independent distributors, and dealers – as well as with direct manufacturing, regional sales, and distribution facilities in Minnesota, Illinois, California and the United Kingdom.

## Table of Contents

	<b>Page</b>
Pumps .....	4
Engine Specified Pumps	
General Service Pumps	
Impellers .....	9
Performance	
Identification	
Kit Information	
Accessories .....	14
Strainers and Brackets	
Service Section .....	15
Pumps by Engine Manufacturer	
Other OEM and General Service Pumps	
Repair Kits .....	28
Technical Guides .....	29
G Series	
R Series	
17000 Series	
18000 Series	
Preventative Maintenance and Inspection	

*Please visit us at [www.sherwoodpumps.com](http://www.sherwoodpumps.com)*

## Engine Specified Pumps

**Model D55, D60, D65, D75**  
Chrysler M225-M440  
(See pages 16-17)



**Model E35**  
(See pages 18-19, 32-33)



**Model G65**  
Perkins  
(See pages 20-21)

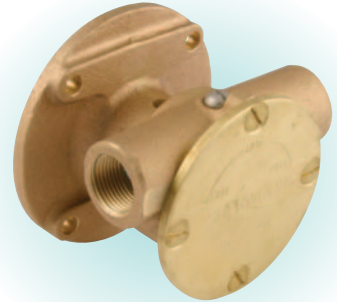

**Model G155**  
(See pages 22-23, 29-31)



**Model G5, G7, G7B, G50**  
Chrysler 318-340  
(See pages 16-17, 29-31)



**Model G20, G21**  
(See pages 22-23, 29-31)



**Model G30-2, G30-2B, G45-1**  
Chris Craft 350 & 454  
(See pages 16-17, 29-31)

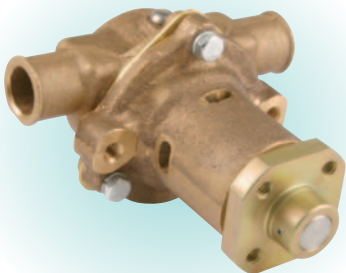

**Model G151, G157**  
Star Power & Marine Power  
(See pages 20-23, 29-31)



**Model GC1, GC4, GC5**  
(See pages 24-25, 29-31)



*The #1 Reason for Premature Engine Wear Is Overheating. To Maintain...*

**Model K75B, L10B**  
(See pages 20-21, 29-31)



**Model M71**  
(See pages 24-25, 29-31)

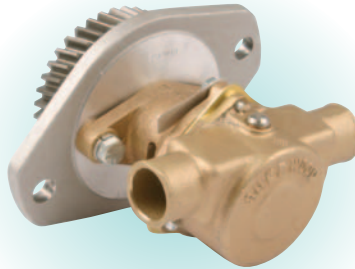

**Model G9901**  
OMC/Volvo 4.3-8.2  
(See pages 20-23, 29-31)



**Model G9903**  
Volvo/OMC 3.0-8.2  
(See pages 20-23, 29-31)



**Model G8001**  
(See pages 24-25)

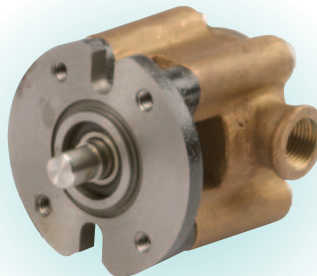

**Model G906, G907**  
(See pages 20-21)

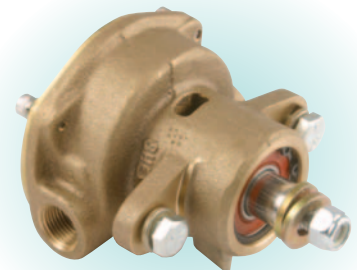

**Model G907P**  
(See pages 20-21)



**Model H5**  
Perkins  
(See pages 20-21)



**Model N10360GX**  
Chris Craft 283  
(See pages 16-17)



*...Engine Performance, Insist Upon Original Engine Specified Sherwood Products.*

## Engine Specified Pumps

**Model P105**  
(See pages 24-25)



**Model R30G, R30G-1**  
(See pages 22-23, 32-33)



**Model R50G, R10870G**  
(See pages 22-23, 32-33)

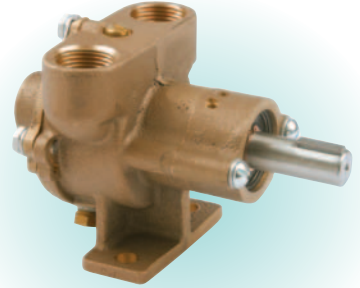

**Model R991**  
Yamaha  
(See pages 22-23)



**Model RPBC**  
Perkins  
(See pages 20-21)



**Model G908**  
(See pages 22-23)



**Model G1006**  
(See pages 24-25)

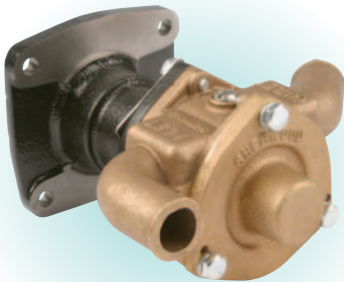

**Model P1012, P1014**  
(See pages 24-25)

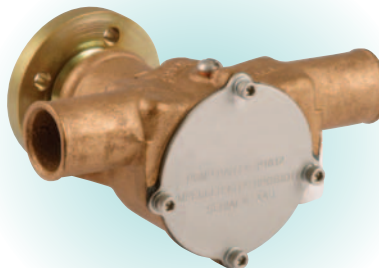

**Model G1801, G1805**  
(See pages 24-25, 36-38)

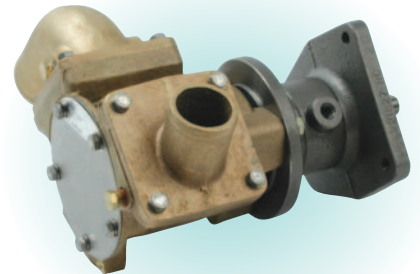

*The #1 Reason for Premature Engine Wear Is Overheating. To Maintain...*

**Model G1806, G18061**  
(See pages 24-25, 36-38)

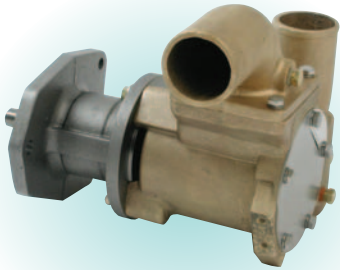

**Model G1807,  
G18071, G18072**  
(See pages 24-25, 36-38)

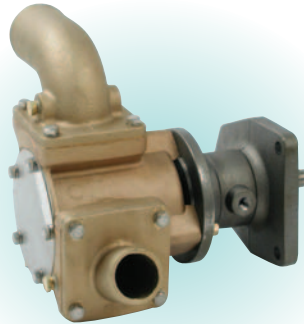

**Model G1808,  
G18081, G18082**  
(See pages 24-25, 36-38)



**Model G1810**  
(See pages 24-25, 36-38)



**Model P176**  
(See pages 26-27, 34-35)

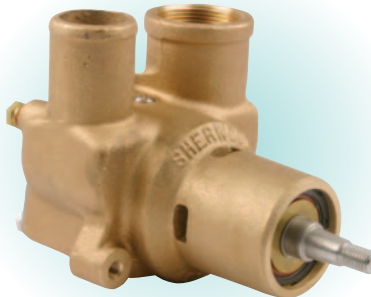

**Model P1710,  
P1726, P1732**  
(See pages 24-27, 34-35)

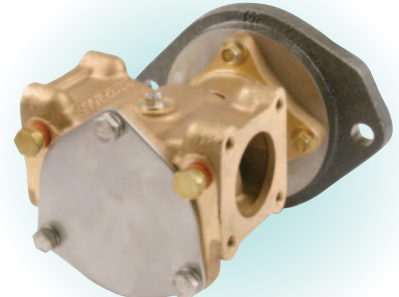

**Model P1711, P1719**  
(See pages 24-25, 34-35)

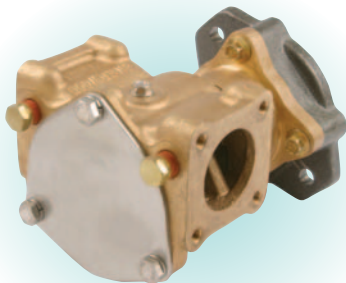

**Model P1716,  
P1722, P173**  
(See pages 24-27, 34-35)



**Model P1727,  
P1730, P1731**  
(See pages 26-27, 34-35)



*...Engine Performance, Insist Upon Original Engine Specified Sherwood Products.*

## General Service Pumps

### G Series

- Mechanical Seal
- Bronze Housing
- Stainless Steel Shaft
- Sealed Ball Bearing
- Excellent for Engine Cooling, Either as Replacement for Obsolete Pump or New Installation

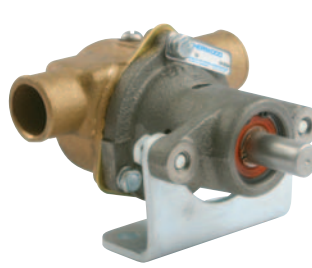

Horizontal Porting G1 & G3



Vertical Porting G2, G4, & G11

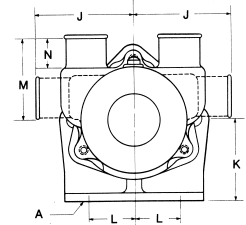
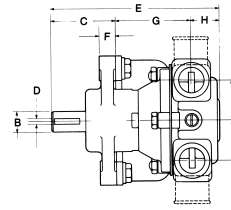
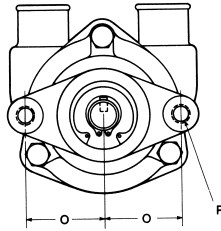

Model No.	Impeller	Port Size	Dimensions (Inches)															
			A	B	C	D	E	F	G	H	I	J	K	L	M	N	O	P
G1	09959	1" Hose	13/32	5/8	2-1/64	3/16	5-1/4	1/2	2-25/64	27/32	1-1/4	2-5/8	2-1/8	1-3/8	-	7/8	1-5/8	3/8
G2	09959	1" Hose	13/32	5/8	2-1/64	3/16	5-1/4	1/2	2-25/64	27/32	1-1/4	-	2-1/8	1-3/8	2-1/4	7/8	1-5/8	3/8
G3	10615	1-1/4" Hose	13/32	5/8	2-1/64	3/16	5-5/8	1/2	2-37/64	1-1/32	1-1/2	2-5/8	2-1/8	1-3/8	-	7/8	1-5/8	3/8
G4	10615	1-1/4" Hose	13/32	5/8	2-1/64	3/16	5-5/8	1/2	2-37/64	1-1/32	1-1/2	-	2-1/8	1-3/8	2-5/16	7/8	1-5/8	3/8
G8	10615	1-1/4" Hose	13/32	5/8	2-1/64	3/16	-	1/2	-	-	1-1/2	-	2-1/8	1-3/8	-	7/8	1-5/8	3/8
G11	09000	1/2" NPT	13/32	5/8	2-1/64	3/16	5-1/4	1/2	2-25/64	27/32	1-1/4	-	2-1/8	1-3/8	2-1/4	7/8	1-5/8	3/8

• See Impeller Flow Curves on Page 9 for Performance

### R Series

- Heavy Duty Design for Pulley Drive or Long Couple
- Mechanical Seal for Extended Seal Life
- Rear Support Bushing for Load Absorption
- Ball Bearing Supported Drive Shaft
- Corrosion Resistant Bronze Constructed
- Neoprene Impeller and Buna Seal - Standard
- Stainless Steel Shaft

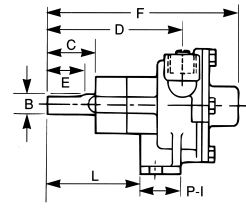
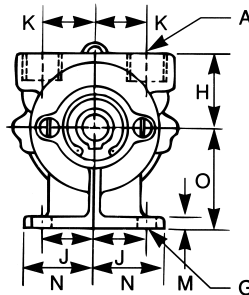
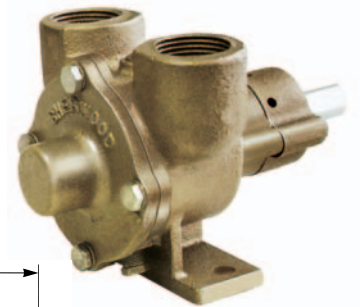

Model No.	Impeller	Port Size	Dimensions (Inches)															
			B	C	D	E	F	G	H	I	J	K	L	M	N	O	P	
R30G	10077	1/2" NPT	.50	1.50	3.56	1.0	5.28	.34	1.47	.75	1.06	1.12	3.09	.25	1.44	1.38	.44	
R50G	09959	3/4" NPT	.63	1.50	4.06	1.0	5.28	.41	1.63	.75	1.12	1.25	3.34	.25	1.50	2.12	.50	
R102	10615	1" NPT	.63	1.50	4.53	1.0	6.66	.41	2.12	.88	1.38	1.50	3.97	.25	1.81	2.12	.56	

• Recommended Horsepower: R30G - 1/2, R50G - 3/4, R102 - 2.  
See Impeller Flow Curves on Page 9 for Performance.



# Impeller Performance

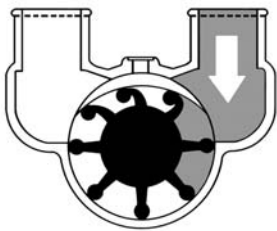
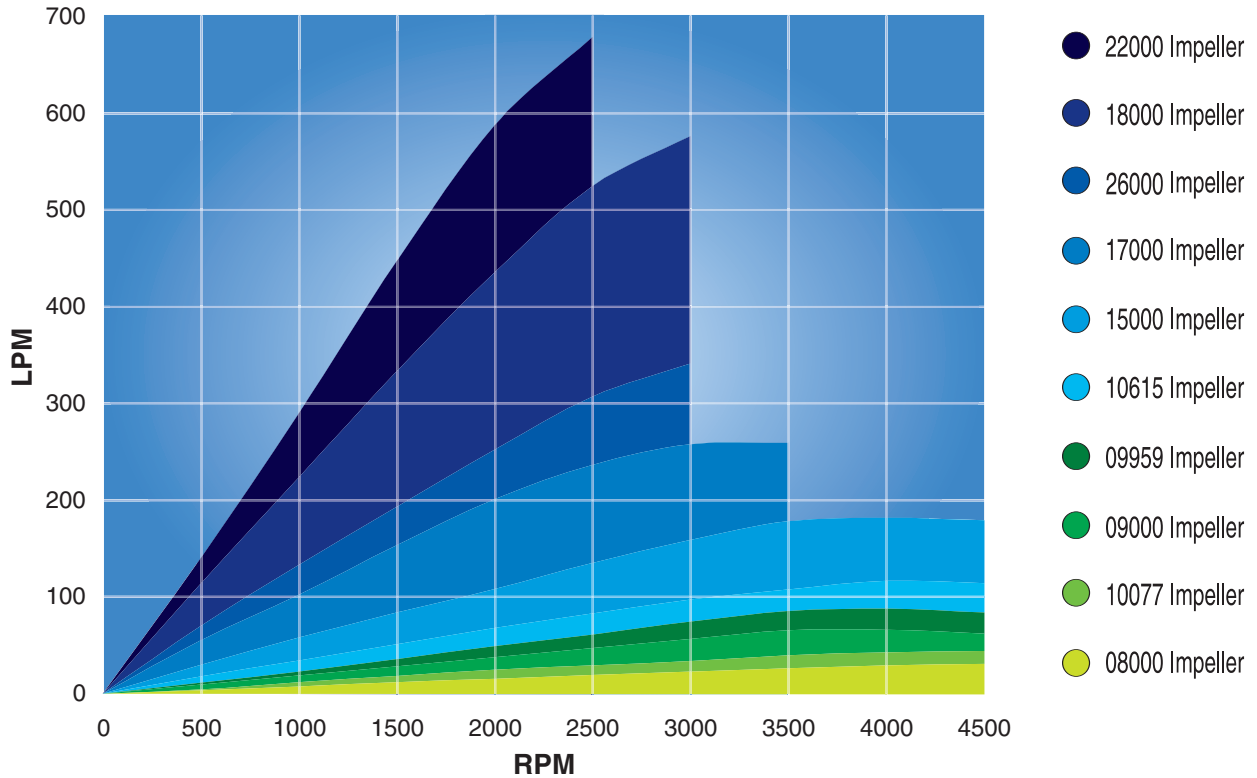

**1** A self-priming vacuum is created as the flexible impeller vanes straighten upon leaving the cam, drawing liquid into the pump.

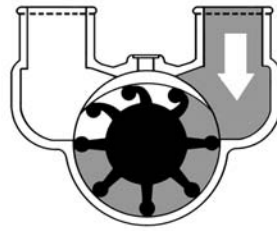

**2** The rotating impeller carries liquid from the inlet to the outlet port. As a consequence of their design, flexible impeller pumps can pass fairly large solids.

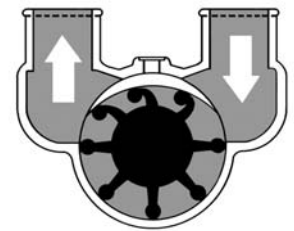

**3** When the flexible impeller vanes regain contact with the cam, they bend and the liquid is discharged from the pump in a uniform flow. Liquids can be pumped in the opposite direction by reversing the rotation of the pump.

## Impeller Specifications

**10615K** Width: 1-5/8" (41mm)  
Diameter: 2-9/16" (65mm)

**15000K** Width: 2" (51mm)  
Diameter: 2-9/16" (65mm)

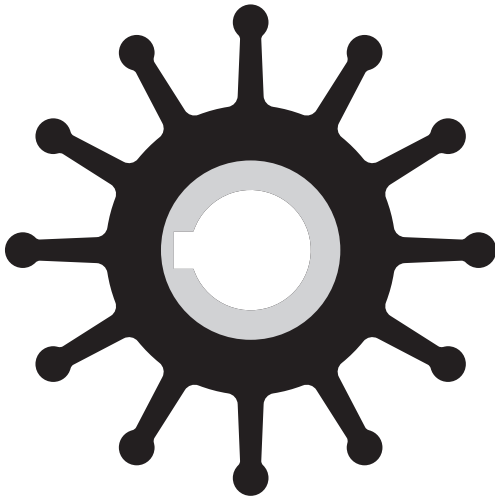

**09959K** Width: 1-1/4" (32mm)  
Diameter: 2-7/16" (62.5mm)

**09000K** Width: 7/8" (22mm)  
Diameter: 2-7/16" (62.5mm)

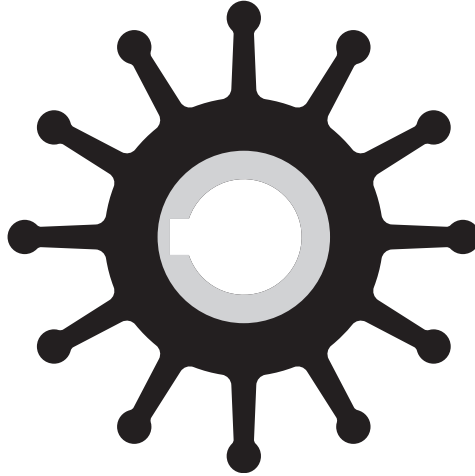

**10077K** Width: 25/32" (20mm)  
Diameter: 2-1/4" (57mm)

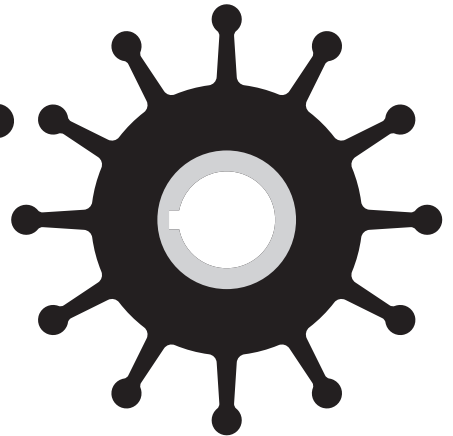

**08000K** Width: 3/4" (19mm)  
Diameter: 1-9/16" (40mm)

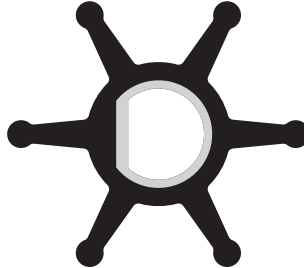

**17000K** Width: 2-7/8" (73mm)  
Diameter: 3-5/16" (84mm)  
**17000PK** Same as 17000K except  
Threaded Insert Version with Puller

**18000K** Width: 4" (102mm)  
Diameter: 3-3/4" (95mm)

**26000K** Width: 3-1/8" (80mm)  
Diameter: 3-3/4" (95mm)

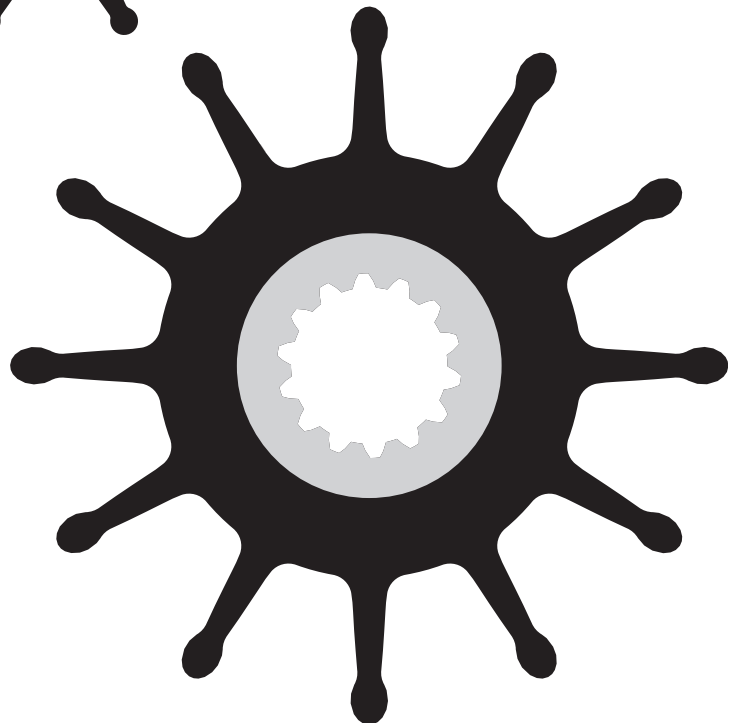
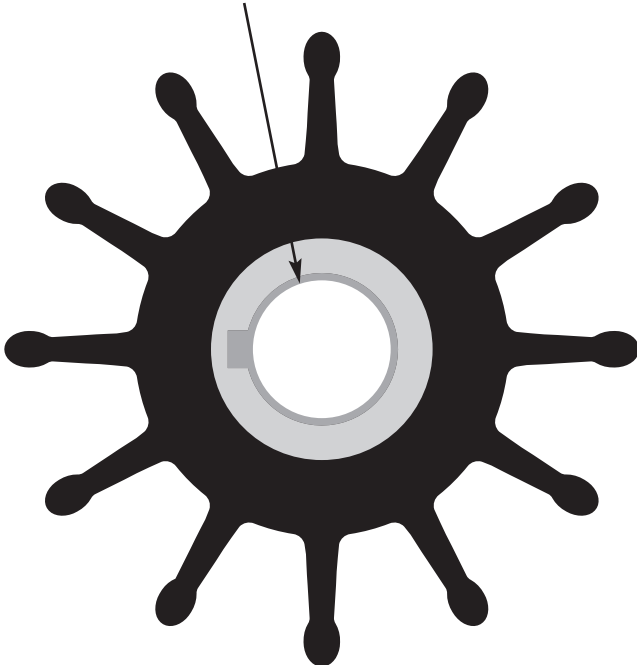

**27000K** Width: 2-7/8" (73mm)  
 Diameter: 3-5/16" (84mm)  
 Splined Impeller

**22000K** Width: 4-5/16" (110mm)  
 Diameter: 4-1/2" (114mm)

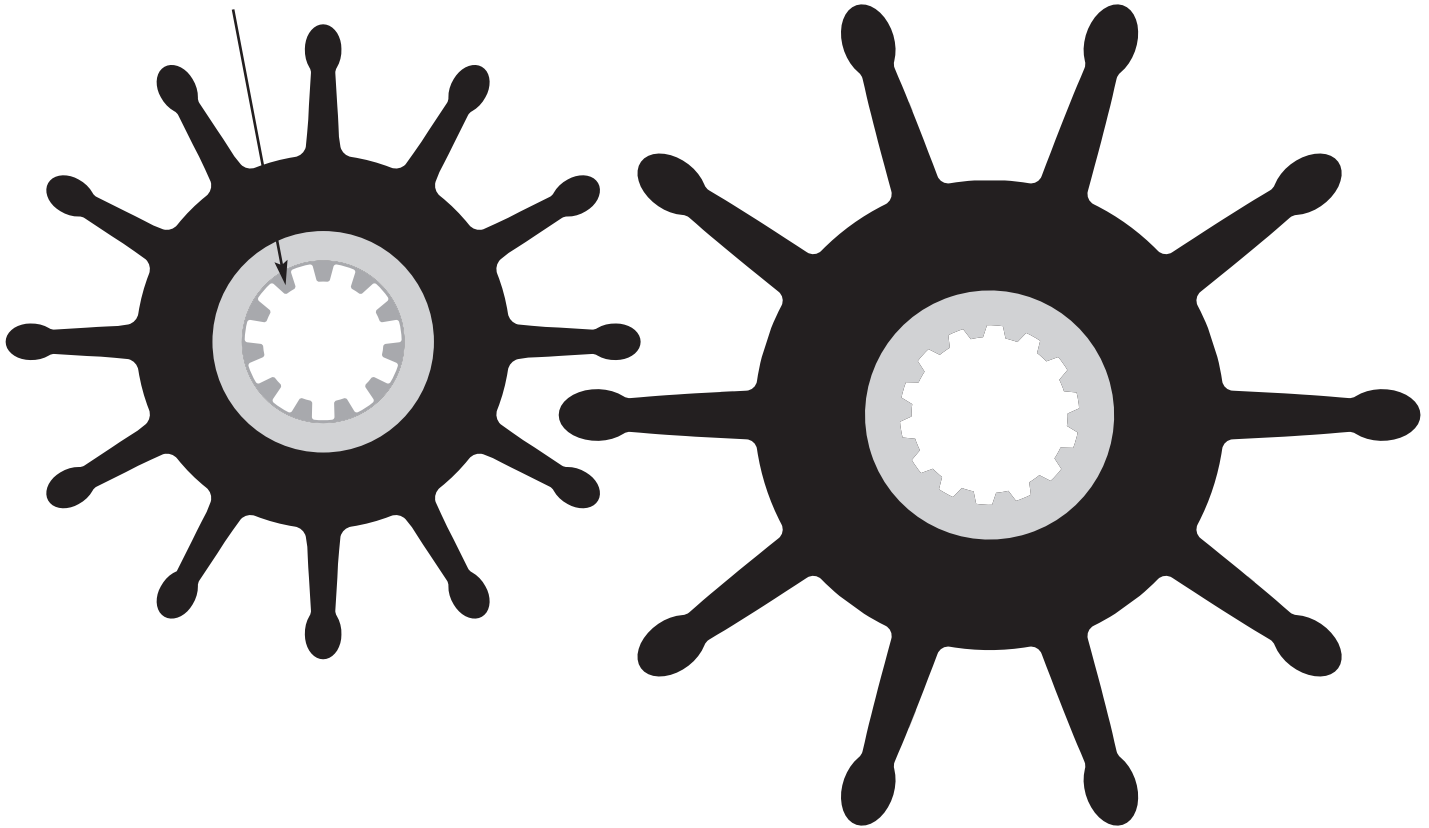

### Additional Impellers

Part #	Diameter	Width	Shaft Diameter	Keyway	Number of Vanes	Material
09979	1-3/4" (40mm)	3/4" (19mm)	3/8"	Pinned	8	Neoprene
18200	2-9/16" (65mm)	2" (51mm)	5/8"	Spline	12	Neoprene
19000	2-9/16" (65mm)	2" (51mm)	3/4"	Special*	12	Neoprene
10187	2-19/32" (66mm)	1-31/32" (50mm)	5/8"	3/16"	9	Neoprene

\* Same as MerCruiser

### Vane Impellers

Vane Assembly Number	Vane Description	Number of Vanes Per Set	Vane Pump Assemblies
09731	1-1/4"L x 13/16"W x 1/8"H	7 (08888)	K9615G, K9635G, K9740G
09745	1-1/4"L x 13/16"W x 1/8"H	14 (08888)	K9529G, K9820G, L9841G, L9850G, L9870G, L9875G
09924	25/32"L x 11/16"W x 1/8"H	16 (09915)	L9910G, M10080G, N10160G

Impeller vanes were used for raw water pump applications prior to the design of the flexible rubber impeller. Vanes are packaged in sets and must be ordered by assembly number.

## Genuine Sherwood Impellers & Impeller Kits

### Patented Impeller Puller

17000, 18000, 22000, 26000, 27000 impellers contain a patented threaded insert design. Patent No. 6,116,855.

### 23631 Puller used for:

17000, 18000, 22000, 26000

### 24412 Puller used for

27000

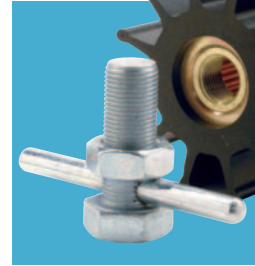

### Impeller Kits Include:

All Gaskets, O-rings, new Technical Service Guide and Engine Specified Impeller for up to 50 Sherwood pumps.

### Impeller Kits Available:

08000K  
09000K  
10077K  
09959K  
10615K  
15000K  
17000K  
17000PK - includes puller  
18000K  
22000K  
26000K  
27000K



### 17000 Impeller Options

**17000C** — Impeller with **thru-key insert** allows for ease of installation in hard-to-reach applications. This impeller is of the same dependable Sherwood design that has been used since the 17000 series impeller was developed.

**17000K** — Impeller Kit is packed with everything needed to replace the impeller using genuine Sherwood parts. Contains thru-key insert that allows for ease of installation in hard-to-reach applications.

- Kit Contains: 17000C Impeller with **thru-key insert**, O-ring, and Rubber cap

**17000** — Patented Impeller with threaded insert for ease of removal and installation.

**17000PK** — Impeller Kit

- Contains: 17000 Impeller with patented **threaded insert**, **Impeller puller** (#23631), and O-ring Patent No. 6,6116,855

# Impeller Removal and Installation

## Threaded Impellers

(17000, 18000, 22000, 26000, and 27000)

### Removal

- Remove the cover.
- Insert the Sherwood puller into the threaded insert.
- Screw the puller against the shaft, lifting the impeller out of the housing or until loose.
- Twist and pull the impeller out of the pump.



### Installation

- Apply a non-petroleum based lubricant to impeller (i.e. silicone or soapy water).
- Install the impeller with a twisting motion onto the shaft.
- Option: Use puller tool to push impeller into pump by loosening and lowering nut until tightens against impeller insert, then turning for installation.
- Then use a small amount of non-petroleum based lubricant to help hold the o-ring in place while replacing the cover.

## Thru-Key Design Impellers

(8000K, 10077K, 09000K, 09959K, 10615K, 15000K, 17000K)

### Removal

- Remove the cover.
- Twist and pull the impeller out of the pump.



### Installation

- Apply a non-petroleum based lubricant to impeller (i.e. silicone or soapy water).
- For non-rock key version pumps, install the key into the shaft prior to installing the impeller.
- Install the impeller with a twisting motion onto the shaft.
- After the impeller is all the way on the shaft and into the housing, rotate the impeller to align the keyway of the shaft to the key slot on the shaft.
- Slide the impeller key into the keyway and if applicable, place the rubber cap over the key opening to prevent possible damage to the cover.
- Then use a small amount of non-petroleum based lubricant to help hold the o-ring in place while replacing the cover.

*To maintain engine performance, insist upon genuine Sherwood impellers.  
Keep it cool with the original!*

## Seawater Strainer and Bracket



- Full Flow Filtering with Ultra Low Pressure Differential
- Easy In-Line Cleaning
- Durable Non-Corrosive Construction
- Quick Clear Bowl Examination
- Lightweight with Optional Mounting Bracket
- Stainless Steel Screens

### Strainer Description

Strainer Number	Port Size	Screen Mesh	Bracket No.
15935	1/2"	20 Mesh	N/A
18004	1/2"	50 Mesh	N/A
18001	3/4"	20 Mesh	14240
18005	1"	20 Mesh	14239
18016	1-1/4"	20 Mesh	14238
18029	1-1/2"	20 Mesh	21930

### Strainer Components

Strainer Number	Screen No.	O-ring No.	Bowl No.
15935	11810	11805	14379
18004	11811	11805	14379
18001	11810	11805	14379
18005	11807	11803	14380
18016	14214	11803	14380
18029	16126	11803	14380



# Pump Service Parts

## Major Pump and Parts Service Section

The following parts list is made available for the identification of major components of raw water pumps currently active in marine engine applications. Although the pump may no longer be a unit in production, it may be a serviceable pump. This is intended to assist the distributors and their dealers with identification and ordering of parts.

Engine Manufacturer		Sherwood Number	Pump Avail	Replacement Pump	Ports		Impeller Kit	Minor Repair Kit	Major Repair Kit	Seal & Seat/Lip Seal
Engine Model	Engine Part Number				Inlet	Outlet				
Gov Life Boat	11658	B11	O	*	1/2" NPT	1/2" NPT	05237/05725		13369	11367
Gov Life Boat	11353	R10870G-01	S	R10870G	3/4" NPT	3/4" NPT	09959K	10997	12937	10927
Gov Life Boat	24143	H70	O	*	7/8"	7/8"	10077K	13367	13366	11628
Gov Life Boat	302648	G903	O	G908	1/2" NPT	1/2" NPT	09000K			12859/18806
Gov Life Boat	42175	G908-01	P	G908	1/2" NPT	1/2" NPT	09000K			12859/18806
Model 283	16.80-10003	N10360GX	S		1/2" NPT	1/2" NPT	(2) 10077K	10244	12301	10546
Model 307-327Q	16.80-28342	D10C	O	*	-	-	10635			10577
Model 307-327Q	16.80-28341	D15CC	O	*	-	-	10557			10577
M383X, M413E, M440X	E-7592-M	P10550G	O	D55	1 1/4"	1 1/4"	09959K & 10615K		12816	10545
		P1730A	S		W/O Port Elbow	W/O Port Elbow	17000K			23799/24250

D10C	Centrifugal recirculating pump clockwise rotation from pulley end
D15CC	Centrifugal recirculating pump counterclockwise rotation from pulley end

O	Obsolete pump, no longer in production
P	Proprietary pump, must purchase through engine manufacturer or their distributor
S	Sherwood pump, purchase direct from Sherwood distributor

R10870G	Pump shown in this column is a direct replacement
*	Asterisk indicates no direct replacement available

NPT indicates threaded port (national pipe thread)	1/2" NPT	1/2" NPT
Dimension indicates outside diameter of port	1 1/4"	1 1/4"
Signifies that the pump is sold without any port elbows	W/O Port Elbow	W/O Port Elbow

For gear pumps, first item drive gear, second item is the idler	05237/05725
Rubber Impeller (2) per pump	(2) 10077K
Pump uses both a 09959 and 10615 impeller	09959K & 10615K

Complete Seal and Seat Assembly	10545
Mechanical Seal followed by the Lip Seal	23799/24250

### GENERAL PARTS INFORMATION

\*Asterisk indicates parts are obsolete.

Blank space indicates part not used in pump design.

ENGINE MANUFACTURER		SHERWOOD NUMBER	PUMP AVAIL	PREPLACEMENT PUMP	PORTS		IMPELLER KIT	MINOR REPAIR KIT	MAJOR REPAIR KIT	SEAL & SEAT/ LIP SEAL	BEARING ASSEMBLY
ENGINE MODEL	ENGINE PART NO.				INLET	OUTLET					
<b>Chris Craft</b>											
Model A		G8456	O	*						*	
Model A		A16	O	*	1"	1"	09959K			10927	4257
Model B		D7704	O	*	3/8"	3/8"				*	*
Model B		D7730	O	*	3/8"	3/8"				*	*
Model B		G8450	O	*	3/8"	3/8"				*	4306
Model B		K9750G	O	*	3/8"	3/8"				10546	4306
Model B		M10261G	O	*	3/8" NPT	3/8" NPT	10077K			10546	4306
Model K		D7669	O	*	1/2"	1/2"				*	*
Model K		D7729	O	*	1/2"	1/2"				*	*
Model K		G8451	O	*	1/2"	1/2"				10522	4306
Model K		K9710G	O	*	1/2"	1/2"				10546	4306
Model K	16.80-10007	M10262G	O	*	1/2" NPT	1/2" NPT				10546	4306
Model M		D7710	O	*	3/4"	3/4"				*	*
Model M		D7731	O	*	3/4"	3/4"				*	*
Model M		G8452	O	*	3/4"	3/4"				*	4306
Model M		K9635G	O	*	3/4"	3/4"				10546	4306
Model M	16.80-10008	M10263G	O	*	3/4" NPT	3/4" NPT	09959K	10685	12246	10545	4306
Model W		G8453	O	*	1"	1"				*	*
Model W		K9740	O	*	1"	1"				10545	4257
Model W	16.80-10009	M10264G	O	*	1" NPT	1" NPT	09959K	10685		10545	4257
Model 283		L9980G	O	N10360GX	1/2"	1/2"				10546	4306
Model 283		L9910G	O	N10360GX	1/2"	1/2"	09924			10546	4306
Model 283		N10160G	O	N10360GX	1/2"	1/2"	09924			10546	*
Model 283		M10095G	O	N10360GX	1/2"	1/2"	(2) 10077K	10244		10546	4306
Model 283	16.80-10003	N10360GX	S		1/2" NPT	1/2" NPT	(2) 10077K	10244	12301	10546	4306
Model 283M		L9980G	O	N10360GX	1/2"	1/2"				10546	4306
Model 283F		Q10780G	O	S11095G	1" NPT	1" NPT				10545	19988
Model 283F	16.80-27555	Q10825CC	O	*	-	-	10557		12249	10577	14055
Model 283F	16.80-27554	Q10830C	O	*	-	-	10635		12249	10577	14055
Model 307-327Q	16.80-18340	D05	S		1"	1"	10615K	11430		10927	(2) 4257
Model 307-327Q	16.80-28342	D10C	O	*	-	-	10635			10577	14055
Model 307-327Q	16.80-28341	D15CC	O	*	-	-	10557			10577	14055
Model 327F		Q10780G	O	S11095G	1" NPT	1" NPT				10545	19988
Model 327F		S11095G	S		1"	1"	10615K			10545	19988
Model 327F		Q10825CC	O	*	-	-	10635			10577	14055
Model 327F		Q10830C	O	*	-	-	10557			10577	14055
Model 427	16.80-10010	S11095G	S		1"	1"	10615K	11102	12308	10545	19988
Model 427	16.80-07808	S11110C	O	*	-	-	10635			10577	14055
Model 427	16.80-11007	S11115CC	O	*	-	-	10557			10577	14055
Model 430		N10450	O	N10360GX	-	-				10545	4257
Model 430		M10080G	O	N10360GX	-	-	09924			10546	4306
Model 430		N10200G	O	N10360GX	-	-	(2) 10077			10546	4306
Model 430		N10370G	O	N10360GX	-	-	(2) 10077			10546	4306
Model 430	16.80-10003	N10360GX	S		1/2" NPT	1/2" NPT	(2) 10077	10244	12301	10546	4306
Model 431		P10670	O	N10360GX	-	-				10545	4257
Model 431		N10490CC	O	*	-	-	10557			10577	14055
Model 431		N10580C	O	*	-	-	10635			10577	14055
Model 350	16.80-18344	G15	S		1"	1"	09959K	23979	12665	12859	(2) 23448
Model 350	16.80-18346	G30-2	S		1"	1"	09959K	23979	12665	12859	(2) 23448
Model 350	16.80-18346	G30-2B	S		1"	1"	09959K	23979	12665	12859	(2) 23448
Model 454	16.80-18347	G45-1	S		1 1/4"	1 1/4"	10615K	23976	23977	12859	(2) 23448
<b>Chrysler Marine</b>											
318 and 360	4142878	G7	S		1 1/4"	1 1/4"	10615K	23976	23977	12859	(2) 23448
318 and 360	4142878	G7B	S		1 1/4"	1 1/4"	10615K	23976	23977	12859	(2) 23448
M80 (CW)	E5913-M	P10560G	O	*	-	-	(2) 09959K			10545	*
M80 (CCW)	E5839-M	P10710G	O	*	-	-	(2) 09959K			10545	*
Slant 6	E-7783-M	P10610G	O	*	-	-	09959K	10685	12252	10545	4257
Slant 6	2659553	A03	O	*	-	-	09959K	11145	12792	10545	4257
M225X	E-8542-M	Q10855G	O	D75	1"	1"	(2) 09959K	12818	12933	10545	19988
M225X	2847632	D75	S		1"	1"	(2) 09959K	10656	12793	10927	4257
M273X, LM318X	E-9327-M	R10935G	O	D60	1"	1"	(2) 09959K	12818	12814	10545	19988
M273X, LM318X	2847630	D60	S		1"	1"	(2) 09959K	10656	12300	10927	4257
M273X, LM318X	E-7584-M	N10390G	O	D60	1"	1"	(2) 09959K	12818	12814	10545	19988
M273X, LM318X	2847631	D65	O	D60	1"	1"	(2) 09959K	10656	12300	10927	4257
M383X, M413E, M440X	E-7592-M	P10550G	O	D55	1 1/4"	1 1/4"	09959K & 10615K			12816	10545
M383X, M413E, M440X	2847629	D55	S		1 1/4"	1"	09959K & 10615K	10922	12299	10927	4257



# Pumps by Engine Manufacturer

SHAFT	CAM	GASKET / O-RING	BUSHING	BODY	CAM SCREW	COVER	HOUSING	WEAR PLATE	KEY	PIN	SLINGER	RETAINING RING	PULLEY / GEAR / HUB / ADAPTER
*				*		*	*		17658	17657	7070		*
11149	10072	10103	6333	*		*	*		4432	1311	1410-0056	(2) 4258/4259 (1)	*
*		(4) 5248		*	*	*	*		17658	17657	7070		
*		(4) 5248	17891/5747	*	*	8453	*		17658	17657	7070		
*		(4) 5248	17891/5747	*	*	8453	*	5795	17658	17657	7070		*
*	*	9484	2075	*	*	*	*	*		17657	7070		
*	10285	10286	2075	*	12686	10279	*		10093	17657	7070	4304	
*		(4) 5248	17891/5747	*	*	*	*	*	17658	17657	7070		
*		(4) 5248	17891/5747	*	*	8453	*	5795	17658	17657	7070		
*		(4) 5248	17891/5747	*	*	8453	*	5795	17658	17657	7070		
*	*	9484	2075	*	*	*	*	*		17657	7070		*
10312	*	10286	2075	*	10195	10279	*	10079	17658	17657	7070	4304	
*		(4) 5248	17891/5747	*	*	*	*	*	17658	17657	7070		
*		(4) 5248	17891/5747	*	*	8453	*	5795	17658	17657	7070		
*		(4) 5248	17891/5747	*	*	8453	*	5795	17658	17657	7070		
*	*	9484	2075	*	*	*	*	*		17657	7070		*
*	10072	10103	6333	*	9919	10094	*	*	4432	17657	14990	4258	
*	*	*	17891/5747	*	*	*	*	*	17658	17657	7070		
*	*	9484	6333	*	*	*	*	*		528	*		*
10276	10072	10103	6333	10274	9919	10094	*	12317	4432	528	14990	4258	
*		*	17891/5747	*	*	*	*	*	17658	528	7070	4304	
*	*	9917/9918	2075	9909	9919	9907	*	*		528			*
*	*	9917/9918	2075	9909	9919	9907	*	*		528			*
10078	10134	9917/9918	2075	9909	9919	9907	*	10079	10093	528		4304	
10078	10134	9917/9918	2075	9909	9919	9907	10416	10079	10093	528		4304	
*		*	2075/5747	*	12686	*	*	*	17658	528	7070	4304	
*		*	6333/*	*	*	*	*	*	4432	9420		4258	10769
		10575				*	*				1410-0056	10574	
		10575				*	*				1410-0056	10574	
11429	10944	10931	6333	11428	10515		11426		4432	1311		(2) 4258/4259 (1)	
		15945				11423	*				1410-0056	10574	
		15945				11423	11419				1410-0056	10574	
*		*	6333/*	*	*	*	*	*	4432	9420		(2) 4258	10769
14212	10944	10971	6333		10515	10182	10957	*	4432	9420		(2) 4258/8781 (1)	10769
		10575					*				1410-0056	10574	
		10575					*				1410-0056	10574	
14212	10944	10971	6333		10515	10182	10957	*	4432	9420		(2) 4258/8781 (1)	10769
							*				1410-0056	10574	
							*				1410-0056	10574	
*		*	6333/*	*	*	*	*	*	17658	528	*	4258	
*	10134	9917	2075	9909	9919	*	*	*		528			*
10078	10134	9917	2075	9909	9919	*	*	*	10093	528		4304	
10078	10134	9917	2075	9909	9919	*	*	*	10093	528		4304	
10078	10134	9917/9918	2075	9909	9919	9907	10416	10079	10093	528		4304	
*		*	6333/*	*	*	*	*	*	17658	528		4258	
		10575				*	*				1410-0056	*	*
		10575				*	*				1410-0056	*	*
12233	15883	12231/12855		12324	10515		12303	12856	4432/12622			12305/(2), 4258/4259 (2)	12323
12612	15883	12231/12855		12328	10515		12303	12856	4432	12791		(3) 4258/4259 (2)	12615
12612	15883	12231/12855		19784	10515		12303	12856	4432	12791		(3) 4258/4259 (2)	12615
12612	10944	12231/12855		12328	10515		12228	12856	4432	12791		(3) 4258/4259 (2)	12615
13363	10929	12231/12855		12227	10515		12952	12856	4432			(3) 4258/4259 (2)	15055
13363	10929	12231/12855		19789	10515		12952	12856	4432			(3) 4258/4259 (2)	15055
*	(2) 10072	(2) 10103	6333	*	(2) 9919	10094	*	*	4432				*
*	(2) 10072	(2) 10103	6333	*	(2) 9919	10094	*	*	4432				*
*	10072	10103	6333	*	9919	10094	*		4432/14096	1311		4258/4259	
*	10072	*	6333	*	9919		*		4432	1311	*	4258/4259	*
10501	(2) 15883	(2) 10609	6333		(2) 10515	*	*	10625	(2) 4432	(2) 413	*	4258/8781	*
11459	(2) 15883	(2) 10609	6333	11454	(2) 10515	10611	10625	(2) 4432/11515	(2) 413	(2) 413		(3) 4258/4259 (1)	12326
10501	(2) 15883	(2) 10609	6333	*	(2) 10515	10913	*	10625	(2) 4432	(2) 413	*	4258	*
11459	(2) 15883	(2) 10609	6333	11454	(2) 10515	10913	10625	(2) 4432/11515	(2) 413	(2) 413		(3) 4258/4259 (1)	12326
10501	(2) 15883	(2) 10609	6333	*	(2) 10515	*	*	10625	(2) 4432/*	(2) 413	*	4258/8781	*
11459	(2) 15883	(2) 10609	6333	11454	(2) 10515	10611	10625	(2) 4432/11515	(2) 413	(2) 413		(3) 4258/4259 (1)	12326
*	15883/10944	10609/10612	6333	*	(2) 10515	*	10625	(2) 4432	(2) 413	(2) 413	*	4258/8781	*
11460	15883/10944	10609/10612	6333	11455	(2) 10515	10611	10625	(2) 4432/11515	(2) 413	(2) 413		(3) 4258/4259 (1)	12326

ENGINE MANUFACTURER		SHERWOOD NUMBER	PUMP AVAIL	PREPLACEMENT PUMP	PORTS		IMPELLER KIT	MINOR REPAIR KIT	MAJOR REPAIR KIT	SEAL & SEAT/ LIP SEAL	BEARING ASSEMBLY
ENGINE MODEL	ENGINE PART NO.				INLET	OUTLET					
<b>Chrysler Marine (continued)</b>											
LM318-X, LM340-X	2846428	C-03	O	G7	-	-	10615K	10999	11068	10927	4257
LM318-X, LM340-X	3675763	G5	O	G7	1 1/4"	1 1/4"	10615K	23976	23977	12859	(2) 23448
LM318-X, LM340-X	3745511	G5-1	O	G7	1 1/4"	1 1/4"	10615K	23976	23977	12859	(2) 23448
LM318-X, LM340-X	3619030	F10	O	G50	1 1/4"	1 1/4"	10615K	10999	11068	10927	4257
LM318-X, LM340-X	3619212	G50	S		1 1/4"	1 1/4"	10615K	23976	23977	12859	(2) 23448
<b>Commander</b>											
302 and 351	CM1-10-610	J70	S		1"	1"	09959K	23979	12665	12859	(2) 23448
302 and 351	C2-10-610	L80	S		1 1/4"	1 1/4"	10615K	23976	23977	12859	(2) 23448
<b>Crusader (Dearborn)</b>											
Model 220,270,300,350	97179	E35	S		1" NPT	1" NPT	10615K	10999	11068	10927	4257
Chevy RH Rotation		L9820G	O	*	-	-	09745			10545	4257
Chevy RH Rotation		L9870G	O	*	-	-	09745			10545	4257
Chevy RH Rotation		M10270G	O	*	1" NPT	1 1/4"	(2)09959K			10545	4257
Chevy LH Rotation		L9841G	O	*	-	-	09745			10545	4257
Chevy LH Rotation		L9875G	O	*	-	-	09745			10545	4257
Chevy LH Rotation		M10280G	O	*	1" NPT	1 1/4"	(2)09959K			10545	4257
Chevy LH Rotation		Q10755G	O	*	-	-	09959K			10545	4257
Chevy LH Rotation	1000269	Q10775G	O	*	-	-	10187		12819	10758	4257
Chevy LH Rotation	1001984	S11085G	O	*	1 1/2"	1"	10187		12819	10758	4257
Chevy RH Rotation		Q10765G	O	*	-	-	09959K			10545	4257
Chevy RH Rotation	1000270	Q10785G	O	*	-	-	10187		12819	10758	4257
Chevy RH Rotation	1001985	S11090G	O	*	1 1/2"	1"	10187		12819	10758	4257
Interceptor		M10210G	O	P10700G	-	-	09959K	10685	12252	10545	4257
Interceptor		N10410G	O	P10700G	-	-	09959K	10685	12252	10545	4257
Interceptor		P10700G	S		3/4" NPT	3/4" NPT	09959K	10685	12252	10545	4257
Interceptor		F15	O	R50G	3/4" NPT	3/4" NPT	09959K			10927	4257
Model 220,270,300,350		S11040G	O	E35	1" NPT	1" NPT	10615K	10999	11068	10927	4257
Model 220,270,300,350		B04	O	E35	1" NPT	1" NPT	10615K	10999	11068	10927	4257
Model 220,270,300,350	40070	P102	O	P105	1 1/4"	1 1/4"	10615K	19355	19354	18652	8490
Model 220,270,300,350		R101	O		1" NPT	1" NPT	10615K	18654	18653	10927	4257
Model 220,270,300,350	40050	P101	P	P1014	1 1/4"	1 1/4"	10615K	19301	19300	12859	(2) 23448
Chevy V6	97512	H10	O	*	1"	1"	09959K	23979	12665	12859	(2) 23448
<b>Escort (SkilTec)</b>											
302 and 351		F75	O	*	1" NPT	1" NPT	10615K		12417	10927	4257
302 and 351	D5MZ8502	G85	S		1 1/4"	1 1/4"	10615K	23976	23977	12859	(2) 23448
<b>Glastron Boat Co.</b>											
121, 182, and 302 CI		G95-1	S		1"	1"	09959K	23979	12665	12859	(2) 23448
<b>Gray Marine</b>											
4 Cyl	G78478	N10510G	O	*	-	-	09959K			10545	4257
4 Cyl	G78972	P10650G	O	*	-	-	09959K		12242	10545	4257
4 Cyl	G77560	L9930G	O	*	3/4" NPT	3/4" NPT	09959K			10545	4257
6 Cly	G77160	K9615G	O	*	-	-	09731			10545	4257
6 Cly	G77475	M10065G	O	*	-	-	09959K			10545	4257
6 Cly	G77560	L9930G	O	*	-	-	09959K			10545	4257
Fireball V8 (CW Rotation)	G75842	K9529G	O	*	-	-	09745			10545	4257
Fireball V8 (CW Rotation)	G77532	L9850G	O	*	-	-	09745			10545	4257
Fireball V8 (CW Rotation)	G80785	R10925G	O	*	-	-	09959K			10545	4257
Fireball V8 (CW Rotation)	G77586	M10180G	O	*	-	-	(2)09959K			10545	4257
Fireball V8 (CCW Rotation)	G80784	R10920G	O	*	-	-	09959K			10545	4257
Fireball V8 (CCW Rotation)	G77585	L9920G	O	*	-	-	(2)09959K			10545	4257
Compact V8 215,225 CCW	G80301	N10460	O	*	-	-	09959K		12250	10513/10514	4257
Compact V8 215,225 CW	G80300	N10470	O	*	3/4" NPT	3/4"	09959K		12250	10513/10514	4257
Gov Engine	G76647	Q10770G	O	*	-	-	09959K	10685		10545	4257
Gov Engine	G80971	R10955G	O	*	-	-	09959K	10685		10545	4257
Gov Engine	G85106	R10970G	O	*	-	-	10615K	10999		10927	4257
Gov Engine	G80561	Q10840	O	*	1/2" NPT	1/2" NPT	10077K		12251	10859/11628	(2) 4306
Gov Engine	G80953	R10945CC	O	*	1 1/2"	1 1/4"	10557	12249		10577	
Gov Engine	G80954	R10950C	O	*	1 1/2"	1 1/4"	10635	12249		10577	

SHAFT	CAM	GASKET / O-RING	BUSHING	BODY	CAM SCREW	COVER	HOUSING	WEAR PLATE	KEY	PIN	SLINGER	RETAINING RING	PULLEY / GEAR / HUB / ADAPTER
*	10944	10612	6333	*	10515	*			4432	1311		(2) 4258/4259	*
12233	10944	12231/12855		12227	10515		12228	12856	4432	11541		(2) 4258/4259 (2)	12326
12233	10929	12231/12855		12227	10515		12952	12856	4432	11541		(2) 4258/4259 (2)	*
*	10944	10612	6333	*	10515	*			4432	1311		(3) 4258/4259	*
12233	10944	12231/12855		12227	10515		12228	12856	4432	11541		(3) 4258/4259, (2) 12305	12323
13274	15883	12231/12855		12328	10515		12303	12856	4432/12622			(3) 4258/4259 (2)	13429
13274	10944	12231/12855		12328	10515		12228	12856	4432/12622			(3) 4258/4259 (2)	13429
11744	10944	10931	6333	11245	10515	10182			4432	(2) 1311		(2) 4258/4259 (1)	97176
*	*	9484	6333	*	*	*	*	*		413		4258/4259	*
*	*	9484	6333	*	*	*	*	*		413		4258/4259	*
10266	*	(2) 10103	6333	*	9919	10094	*	*	(2) 4432	413		(2) 4258/4259	*
*	*	9484	6333	*	*	*	*	*		413		4258/5328	*
*	*	9484	6333	*	*	*	*	*		413		4258/5328	*
10266	*	(2) 10103	6333	*	9919	10094	*	*	(2) 4432	413		(2) 4258/4259	*
*	15883	*	6333	*	10515	*	*	*	4432	1311		(2) 4258/4259	*
10748	10944	10752	6333	*	10515	*	*	*	4432	1311		(2) 4258/4259	*
10748	10944	10752	6333	*	10515	*	*	*	4432	1311		(2) 4258/4259	*
*	15883	*	6333	*	10515	*	*	*	4432	1311		(2) 4258/4259	*
10748	10094	10752	6333	*	10822	*	*	*	4432	1311		(2) 4258/4259	*
10748	10094	10752	6333	*	10822	*	*	*	4432	1311		(2) 4258/4259	*
10256	10072	10103	6333	*	9919	10094		10254	4432	1311		4258/4259	*
10256	10072	10103	6333	*	9919	10094		10254	4432	1311		4258/4259	*
10256	10072	10103	6333	10662	9919	10094		10254	4432	1311		(2) 4258/4259	*
10852	10072	10103	6333	10176	9919	10094	15104		(2) 4432	1311		(3) 4258/4259	*
10948	10944	10931	6333	*	10515	10182			4432	1311		4258/4259	97176
11744	10944	10931	6333	11245	10515	10182			4432	1311		4258/4259	97176
19308	10944	12231		21378	10515	21120			4432			5126/6837	19275
18466	10944	12231	6333		10515	18468	18467		12841			(3) 4258/4259 (1)	
19293	10944	19251		19294	10515	19291		19295	4432			(2) 4258/4259 (1)	97176
12596	15883	12231/12855		12328	10515		12303	12856	4432			(2) 4258/4259 (2)	97176
12316	10944	10971	6333		10515	10182	*	*	4432	1311		(2) 4258/4259	10769
12596	10944	12231/12855		12328	10515		12228	12856	4432	9420		(3) 4258/4259 (2)	10769
12664	15883	12231/12855		12328	10515		12303	12856	4432	11543		(3) 4258/4259 (2)	12636
*	10072	10103	6333	*	9919	10094	*		4432	1311		4258/4259	*
*	10072	10103	6333	*	9919	10094	*		4432	1311		4258/4259	*
*	10072	10103	6333	*	9919	10094			4432	1311		4258/4259	*
*	*	9484	6333	*	*	*		*		1311		4258/4259	*
*	10072	9484	6333	*	9919	*		*	4432	1311		4258/4259	*
*	10072	10103	6333	*	9919	10094			4432	1311		4258/4259	*
*	*	9484	6333	*	*	*	*	*		*		4258/4259	*
*	*	9484	6333	*	*	*	*	*		413		4258/4259	*
*	10072	(2) 10103	6333	*	9919	10094	*	*	4432	413		4258/4259	*
10266	(2) 10072	(2) 10103	6333	*	9919	10094	*	*	4432	413		4258/4259	*
*	10072	(2) 10103	6333	*	9919	10094	*	*	4432	413		4258/4259	*
10266	(2) 10072	(2) 10103	6333	*	9919	10094	*	*	4432	413		4258/4259	*
*	10072	10512		*	10515	*	*	*	4432	1311	*	5328/4259	*
*	10072	10512		*	10515	*	*	*	4432	1311	*	5328/4259	*
*	10072	10103	6333	*	10515	10094			4432	1311		(3) 4258/4259	*
*	10072	10103	6333	*	10515	10094			4432	1311		(3) 4258/4259	*
*	10929	10931	6333	*	10515	10182			4432	1311	7070	4258/4259	*
10858	10285	10286		*	10195	10593			10093	*		4303/4304	*
14055		10575				*	*			*		10574	*
14055		10575				*	*			*		10574	*

ENGINE MANUFACTURER		SHERWOOD NUMBER	PUMP AVAIL	PREPLACEMENT PUMP	PORTS		IMPELLER KIT	MINOR REPAIR KIT	MAJOR REPAIR KIT	SEAL & SEAT/ LIP SEAL	BEARING ASSEMBLY
ENGINE MODEL	ENGINE PART NO.				INLET	OUTLET					
<b>Interceptor</b>		M10210G	O	P10700G	-	-	09959K	10685	12252	10545	4257
		N10410G	O	P10700G	-	-	09959K	10685	12252	10545	4257
		P10700G	S		3/4" NPT	3/4" NPT	09959K	10685	12252	10545	4257
		F15	O	R50G	3/4" NPT	3/4" NPT	09959K			10927	4257
<b>Isuzu</b>											
4, 6 Cyl Diesel	X-26230-1023	K90	S		1 1/4"	1 1/4"	10615K	23976	23977	12859	(2) 23448
<b>Kohler</b>											
4, 6 Cyl Diesel		G906P	O	**	3/8" NPT	3/8" NPT	09000K			18570	(2) 23448
Ford		G907P-01	S	G907P	3/8" NPT	3/8" NPT	09000K			22546	(2) 23448
4-6.5 KW Gas		G907 -01	S	G907	3/8" NPT	3/8" NPT	09000K			18035/10926	(2) 23448
<b>Lenco</b>											
		L90	O	G7	1 1/4"	1 1/4"	10615K	23976	23977	12859	(2) 23448
<b>Marine Corp. of Amer. (See StarPower)</b>											
<b>Marine Power</b>											
		G157	S		1 1/2"	1 1/2"	15000K	23980	23981	12859	(2) 23448
		P105	S		1 1/4"	1 1/4"	10615K	10615K	19354	18652	8490
<b>North American Engine</b>											
6.2L Diesel		G56	S		1 1/4"	1 1/4"	10615K	23976	23977	12859	(2) 23448
<b>Onan</b>											
12MDJC-15 MDJF		RPGC	O	*	3/4" NPT	3/4" NPT	09959K	10685	12246	10545	4306
30MDEH-50MDEG		RPGC	O	*	3/4" NPT	3/4" NPT	09959K	10685	12246	10545	4306
4Cyl Diesel		K75	O	K75B	1"	1"	09959K	23979	12665	12859	(2) 23448
4Cyl Diesel		K75B	S		1"	1"	09959K	23979	12665	12859	(2) 23448
5Cyl Diesel		L10	O	L10B	1 1/4"	1 1/4"	10615K	23976	23977	12859	(2) 23448
5Cyl Diesel		L10B	S		1 1/4"	1 1/4"	10615K	23976	23977	12859	(2) 23448
5Cyl Diesel		G905	O		1"	1"	09000K			12859/18570	(2) 23448
5Cyl Diesel		G1004	O	G1006	1"	1"	10615K	10615K	22014	21208/21209	(2) 23448
5Cyl Diesel		G1005	O	G1006	1"	1"	10615K	10615K	22014	21208/21209	(2) 23448
<b>Osco Motors</b>											
		P105	S		1 1/4"	1 1/4"	10615K	10615K	19354	18652	8490
<b>Owens Flagship Marine</b>											
Model V8	6587	L9887	O	*	-	-				7269/10546	*
		M10230	O	*	-	-				7269/10546	*
		Q10750	O	*	-	-				10545	*
<b>OMC</b>											
In Board	981939	G45-2	O	G46	1 1/4"	1 1/4"	10615K	23976	23977	12859	(2) 23448
V8 Chevy	981937	H-85	O		1 1/4"	1 1/4"	10615K	23976	23977	12859	(2) 23448
V8 Chevy	985096	G46	S		1 1/4"	1 1/4"	10615K	23976	23977	12859	(2) 23448
6-8 Cyl	3852398	G9901	S		1 1/4"	1"	09959K	23979	12665	12859	(2) 23448
4Cyl	3852399	G9902	O	G9903	1 1/4"	1"	09959K	23979	12665	12859	(2) 23448
4Cyl	3855079	G9903	S		1 1/4"	1"	09959K	23979	12665	12859	(2) 23448
<b>Palmer</b>											
I.H. 60		E20	O	*	1/2" NPT	1/2" NPT	10077K			10859/11628	4306
<b>Pathfinder Volkswagon Eng.</b>											
4 Cyl		J90	O	*	1"	1"	09959K			12859	*
<b>Perkins Engine U.S.</b>											
40-107 Diesel		B06	O	G65	3/4" NPT	3/4" NPT	09959K	09959K	11421	11237/10514	*
40-108 Diesel	NA003335	G65	S		3/4" NPT	3/4" NPT	09959K	09959K	12221	10514	(2) 23448
4-154 Diesel	NA005576	H5	S		1"	1"	09959K	12981	12980	10514/06602	(2) 4257
6-354 Diesel	NA001175	RPBC	S		1" NPT	1" NPT	10615K	10999	11068	10927	4257

\*\* Kohler Replacement for "G-906P with pulley" is G-907P; "without pulley", use G-906.

SHAFT	CAM	GASKET / O-RING	BUSHING	BODY	CAM SCREW	COVER	HOUSING	WEAR PLATE	KEY	PIN	SLINGER	RETAINING RING	PULLEY / GEAR / HUB / ADAPTER
10256	10072	10103	6333	*	9919	10094		10254	4432	1311		4258/4259	
10256	10072	10103	6333	*	9919	10094		10254	4432	1311		4258/4259	
10256	10072	10103	6333	10662	9919	10094		10254	4432	1311		(2) 4258/4259	
10852	10072	10103	6333	10176	9919	10094	15104		(2) 4432	1311		(3) 4258/4259	
12596	10944	12231/12855		12227	10515		12228	12856	4432			(3) 4258/4259 (2)	*
18569	18663	19964			10195	24125	19963		13777			4258/4259	19967
21861	18663	19964			10195	24125	21862		13777			(2) 4258/4259	21859
21861	18663	19964			10195	24125	21862		13777			(2) 4258/4259 (1)	
12233	10944	12231/12855		12227	10515		12228	12856	4432/12622	11541		12305 (2) 4258/4259	12326/12393
21231	18314	12231/12855		12227	10515		17684	12856	4432			(3) 4258/4259 (2)	
19308	10944	12231		21378	10515	21120			4432			5126/6837	19275
12596	10944	12855/12231		12328	10515		12907	12856	4432	9420		(2) 4258/4259 (3)	10769
11409	10072	10103	6333	*	9919	10094			4432	1311	14990	4258/5484	
11409	10072	10103	6333	*	9919	10094			4432	1311	14990	4258/5484	
13363	15883	12231/12855		*	10515		13793	12856	4432			(3) 4258/4259 (2)	13795
13363	15883	12231/12855		19948	10515		13793	12856	4432			(3) 4258/4259 (2)	13795
13363	10929	12231/12855		*	10515		13899	12856	4432			(3) 4258/4259 (2)	13795
13363	10929	12231/12855		19948	10515		13899	12856	4432			(3) 4258/4259 (2)	13795
*		(2) 19964/19257		*		*	19201	*				(3) 4258/4259	
21207	10929	12231		21122	10515	21173	21150	21163	4432			4258/4259 (2)	
21207	10929	12231		21122	10515	21173	21150	21163	4432			4258/4259 (2)	
19308	10944	12231		21378	10515	21120			4432			5126/6837	19275
*		(2) 5248	2075 (2) 5747	*	*	8453	*	*	17658	1311		4304	*
*		*	2075 (2) 5747	*	*	*	*	*	17658	1311		4304	*
*		*	6333 (2)/*	*	*	*	*	*	17658	1311		4304	*
12233	10929	12231/12855		12328	10515		12952	12856	4432/12622	11541		(2) 4258/4259 (2)	12326
12596	10929	12231/12855		12328	10515	*	12952	12856	4432			(3) 4258/4259 (2)	*
13363	10929	12231/12855		12328	10515		12952	12856	4432			(3) 4258/4259 (2)	15048
13363	15883	12231/12855		21153	10515		21151		4432			(3) 4258/4259	21154
13363	15883	12231/12855		21153	10515		21151		4432			(3) 4258/4259	21175
13363	15883	12231/12855		21759	10515		21151		4432			(3) 4258/4259	21175
11747	10285	10286		*	10195	10593			10093			4303/4304	
*	*	*	*		9919	*	*		4432	*		4258/12840	
*	10072	11360		*	10515	11389			4432				
12444	10072	11360		12440	10515	11389			4432				
13272	15883	12231		11794	10515	11795			4432/13271			4259/12582	
11374	10944	10931	6333	11370	10515	10182			4432/10093	(2) 1311	14990	(3) 4258/4259 (1)	

ENGINE MANUFACTURER		SHERWOOD NUMBER	PUMP AVAIL	PREPLACEMENT PUMP	PORTS		IMPELLER KIT	MINOR REPAIR KIT	MAJOR REPAIR KIT	SEAL & SEAT/ LIP SEAL	BEARING ASSEMBLY
ENGINE MODEL	ENGINE PART NO.				INLET	OUTLET					
<b>Pleasurecraft Marine</b>											
Chevy 454		G55-2	P		1 1/4"	1 1/4"	10615K	23976	23977	12859	(2) 23448
302 and 351		G20	O	G21	1"	1"	09959K	23979	12665	12859	(2) 23448
302 and 351		G21-01	P	G21	1"	1"	09959K	23979	12665	12859	(2) 23448
Mitsubishi 4 Cyl		G22-01	P	G22	-	-	09959K	23979	12665	12859	(2) 23448
7.3L Diesel		G26-01	P	G26	1 1/4"	1 1/4"	10615K	23976	23977	12859	(2) 23448
<b>StarPower</b>											
Inboard		G151	S		1 1/2"	1 1/2"	15000K	23980	23981	12859	(2) 23448
Stern Drive	800790MI	G155	S		1 1/2"	1 1/2"	15000K	23980	23981	12859	(2) 23448
<b>Universal Medalist</b>											
Atomic Four		L9960	O	T11165	-	-	09979			*	
Atomic Four		T11165	O	*	3/8"	3/8"	09979	12949		10514	
Utility Four		T11166	O	*	-	-	09979	12949		10514	
Model OK-OL		L9790G	O	*	-	-	09732			10546	4306
Model OK-OL		Q10805G	O	*	3/8"	3/8"	10077K			10546	4306
Sabre V6		R10930G	O	*	3/4"	3/4"	09959K	10997		10545	4257
Light Plants		E05	O	R30G	1/2"	1/2"	10077K	10996	24025	11367	4306
Light Plants		R10870G	S		3/4" NPT	3/4" NPT	09959K	10997	12937	10927	4257
Light Plants	299805	H80A	O	G908	3/8"	3/8"	12336	11876		(2) 10514	
Light Plants	300986	M5	O	G908	3/8"	3/8"	12336	11876		(2) 10514	
Light Plants	302648	G903	O	G908	1/2"	1/2"	09000K			12859/18806	(2) 23448
<b>U.S. Marine</b>											
351 Ford		P151	S		1 1/4"	1 1/4"	15000K			18652	(2) 18662
<b>Volvo Penta</b>											
		G30-2	S		1"	1"	09959K	23979	12665	12859	(2) 23448
		G85	S		1 1/4"	1 1/4"	10615K	23976	23977	12859	(2) 23448
		P105	S		1 1/4"	1 1/4"	10615K	10615K	19354	18652	8490
6-8 Cyl	3852398	G9901	S		1 1/4"	1"	09959K	23979	12665	12859	(2) 23448
4Cyl	3852399	G9902	O	G9903	1 1/4"	1"	09959K	23979	12665	12859	(2) 23448
4Cyl	3855079	G9903	S		1 1/4"	1"	09959K	23979	12665	12859	(2) 23448
<b>J.H. Westerbeke Corp.</b>											
Pilot 10-20		A20	O	F85	3/8" NPT	3/8" NPT	10077K			10927/11237	*
Pilot 10-20	16423	F85	S		1/2" NPT	1/2" NPT	09959K		12221	10514	(2) 23448
Diesel 4 Cyl	16432	F95	S		3/4" NPT	3/4" NPT	10615K	10999	12333	10927	21972
Diesel 6 Cyl	16432	F95	S		3/4" NPT	3/4" NPT	10615K	10999	12333	10927	21972
Diesel 6 Cyl	24102	R30G-1-01	P	R30G-1	1/2" NPT	1/2" NPT	10077K	10996	24025	11367	4306
Gov Life Boat	11658	B11	O		1/2" NPT	1/2" NPT	05237/05725		13369	11367	11365
Gov Life Boat	11353	R10870G-01	S	R10870G	3/4" NPT	3/4" NPT	09959K	10997	12937	10927	4257
Gov Life Boat	24143	H70	O	*	7/8"	7/8"	10077K	13367	13366	11628	
Gov Life Boat	302648	G903	O	G908	1/2" NPT	1/2" NPT	09000K			12859/18806	(2) 23448
Gov Life Boat	42175	G908-01	P	G908	1/2" NPT	1/2" NPT	09000K			12859/18806	(2) 23448
<b>Whittaker Corp.</b>											
		S4-1	S		1/2" NPT	1/2" NPT	(2) 00456			10927	4257
<b>Yamaha</b>											
4.3 V6, 305/350 Chevy	10100000	R991	S		1 1/4"	1 1/4"	09959K	09959K	18655	10927	4257

SHAFT	CAM	GASKET / O-RING	BUSHING	BODY	CAM SCREW	COVER	HOUSING	WEAR PLATE	KEY	PIN	SLINGER	RETAINING RING	PULLEY / GEAR / HUB / ADAPTER
12596	10944	12231/12855		12328	10515		12907	12856	4432	9420		(3) 4258/4259 (2)	12926
12367	15883	12231/12855		12328	10515		12303	12856	4432/12622	11541		4259/4258/12305	*
13363	15883	12231/12855		12328	10515		12303	12856	4432			(3) 4258/4259 (2)	19729
13363	15883	12231/12855		17501	10515		12303	12856	4432			(3) 4258/4259 (2)	13362
13363	10944	12231/12855		17501	10515		12228	12856	4432			(3) 4258/4259 (2)	19729
19570	18314	12231/12855		12227	12857		17684	12856	4432			(3) 4258/4259 (2)	15055
19570	18314	12231/12855		12227	12857		19880	12856	4432			(3) 4258/4259 (2)	15055
*	*	*		*	*	*					*		
10991	*	*		*	*	*							
10991	*	*		*	*	*							
*	*	9484	2075	*	*	*		*		17657	7070		*
*	10285	10286	2075	*	10195	10279			10093	1311	7070	4304	
*	10162	10103	6333	*	*	10094	*		4432	1311		4258/4259	
10289	10285	10197/10286	2075	10596	10195	10279			10093	1311		4303/4304	
*	10072	10171/10103	6333	*	9919	10094	15104		4432/12622	1311		4258/4259	
11873	*	10286	11519	*	10822	10593			10093			12863	
13833	*	10286	11519	*	10822	10593			10093			12863	
*	18663	12231/12855		*	10195		18451	12856	18576		1410-0056	(3) 4258/4259 (1)	
18671	18398	12231			10515	18509	18660		4432		14990	6837/8781	18507
12612	15883	12231/12855		12328	10515	12856	12303	12856	4432	12791		(3) 4258/4259 (2)	12615
12596	10944	12231/12855		12328	10515		12228	12856	4432	9420		(3) 4258/4259 (2)	10769
19308	10944	12231		21378	10515	21120			4432			5126/6837	19275
13363	15883	12231/12855		21153	10515		21151		4432			(3) 4258/4259	21154
13363	15883	12231/12855		21153	10515		21151		4432			(3) 4258/4259	21175
13363	15883	12231/12855		21759	10515		21151		4432			(3) 4258/4259	21175
*	*	*		*	344	10593			10093			4258	
12444	10072	11360		12210	10515	12220			4432				
12226	10929	10931	6333	12225	10515	10182			4432	(2) 1311	7070	(3) 4258/4259 (1)	
12226	10929	10931	6333	12225	10515	10182			4432	(2) 1311	7070	(3) 4258/4259 (1)	
11854	10285	10197/10286	2075	10596	10195	10279	15103		10093/13370	(2) 1311		4303/4304 (3)	
11363/5247		(2) 5248	5747/17891	*	10195	8453	5249			(4) 1311	7269	4304	
10852	15883	10103/10171	6333	10176	9919	10094	15104		4432/12622	(2) 1311		(3) 4258/4259	
11882	10285	11885	11518	*	10195	*			10093		7070	(2) 12863	
*	18663	12231/12855		*	10195		18451	12856	18576		1410-0056	(3) 4258/4259 (1)	
22796	18663	12231/12855		22795	10195		18451	12856	18576		1410-0056	(3) 4258/4259 (1)	
5782/6394		4263/252	6333	6438		11485	11415		4432/12622			(3) 4258/4259 (1)	
18464	15883	12231	6333		10515	18428	18427		12841			(3) 4258/4259 (1)	18446

SHERWOOD NUMBER	PUMP AVAIL	REPLACEMENT PUMP	PORTS		IMPELLER KIT	MINOR REPAIR KIT	MAJOR REPAIR KIT	SEAL & SEAT/ LIP SEAL	BEARING ASSEMBLY	SHAFT
			INLET	OUTLET						
G1	S		1"	1"	09959K	23979	12665	12859	(2) 23448	11877
G1006	S		1"	1"	10615K	10615K	22276	22177/21208	23448	22143
G1006-01	P	G1006	1"	1"	10615K	10615K	22276	22177/21208	23448	22143
G1008-01	P		1"	1"	10615K	10615K	22276	22177/21208	8490	23801
G11	S		1/2" NPT	1/2" NPT	09000K			12859	(2) 23448	21578
G1503	S		1 1/2"	1 1/2"	15000K	23980	23256	12859/12966	(2) 23448	23228
G1503-01	P	G1503	1 1/2"	1 1/2"	15000K	23980	23256	12859/12966	(2) 23448	23228
G1503-02	P	G1503	1 1/2"	1 1/2"	15000K	23980	23256	12859/12966	(2) 23448	23228
G1503-03	P	G1503	1 1/2"	1 1/2"	15000K			24054/12966	(2) 23448	23228
G151	S		1 1/2"	1 1/2"	15000K	23980	23981	12859	(2) 23448	19570
G155	S		1 1/2"	1 1/2"	15000K	23980	23981	12859	(2) 23448	19570
G1801	O		2 1/2"	2"	18000K	21351	21352	19878/19869	24000 Shaft Bearing Assy†	
G1804	O		2 1/2"	2"	18000K	24004	24006	19878/19869	24001 Shaft Bearing Assy†	
G1805	P		2 1/2"	2"	18000K	24023	24024	19878/19869	24000 Shaft Bearing Assy†	
G1806	O		2 1/2"	2 1/2"	18000K	24004	24006	19878/19869	24001 Shaft Bearing Assy†	
G18061-01	P		2 1/2"	2 1/2"	18000K	24004	24006	23837/19869	24001 Shaft Bearing Assy†	
G1807	P		2 1/2"	2"	18000K	24023	24024	19878/19869	24001 Shaft Bearing Assy†	
G18071-01	P		2 1/2"	2"	18000K	24023	24024	23837/19869	24001 Shaft Bearing Assy†	
G1808	O		3 3/4"	3 3/4"	18000K	24004	24007	19878/23045	24002 Shaft Bearing Assy†	
G18081-01	P		3 3/4"	3 3/4"	18000K	24004	24007	23837/23045	24002 Shaft Bearing Assy†	
G18082-01	P		3 3/4"	3 3/4"	18000K	24004	24007	23837/23045	24463 Shaft Bearing Assy†	
G1810-01	P	G1810X	2 1/2"	2"	18000K	24005	24008	23512/23045	24003 Shaft Bearing Assy†	
G1810X	S		W/O Port Elbow	W/O Port Elbow	18000K	24005	24008	23512/23045	24003 Shaft Bearing Assy†	
G1811-01	P	G1810X	2 1/2"	2"	18000K	24005	24008	23512/23045	24003 Shaft Bearing Assy†	
G2	S		1"	1"	09959K	23979	12665	12859	(2) 23448	11877
G2201-01	O		3 3/4"	3 3/4"	22000K	23234	23236	23087/23088	(2)23089	23058
G22011-01	P		3 3/4"	3 3/4"	22000K	23234	23938	23906/23088	24464 Shaft Bearing Assy†	
G22012-01	P		3 3/4"	3 3/4"	22000K	23234	23938	23906/23088	24465 Shaft Bearing Assy†	
G2601-01	P	G2601X	2 1/2"	W/O Port Elbow	26000K	24227	24228	23837/19869	24223 Shaft Bearing Assy†	
G2601-02	P	G2601X	W/O Port Elbow	W/O Port Elbow	26000K	24227	24228	23837/19869	24223 Shaft Bearing Assy†	
G2601X	S		W/O Port Elbow	W/O Port Elbow	26000K	24227	24228	23837/19869	24223 Shaft Bearing Assy†	
G3	S		1-1/4"	1-1/4"	10615K	23976	23977	12859	(2) 23448	11877
G4	S		1-1/4"	1-1/4"	10615K	23976	23977	12859	(2) 23448	11877
G701-01	P		1"	1"	10077K		22784	18037/21751	(2) 23448	22769
G8	S		1-1/4"	1-1/4"	10615K	23976	23977	12859	(2) 23448	11877
G8001	S		3/8" NPT	3/8" NPT	8000K			23459	(2) 23323	23445
G8001-01	P	G8001	3/8" NPT	3/8" NPT	8000K			23459	(2) 23323	23445
G8002-01	P		3/8" NPT	3/8" NPT	8000K			23459	(2) 23448	23679
G909-01	P		3/8" NPT	3/8" NPT	09000K			22546	(2) 23448	24171
GC1	S		1 1/2"	1 1/2"	15000K	23980	23981	12859/10514	(2) 23448	21069
GC1-01	P	GC1	1 1/2"	1 1/2"	15000K	23980	23981	12859/10514	(2) 23448	21069
GC4	S		1 1/2"	1 1/2"	15000K	23980	23981	12859/10514	(2) 23448	21069
GC5	S		1 1/2"	1 1/2"	15000K	23980	23981	12859/10514	(2) 23448	19843
GC5-01	P	GC5	1 1/2"	1 1/2"	15000K	23980	23981	12859/10514	(2) 23448	19843
GP8001-01	O	G8001	3/8" NPT	3/8" NPT	8000K			23459	(2) 23323	23445
GP8002-01	O		3/8" NPT	3/8" NPT	8000K			23459	(2) 23448	23679
M71	S		1 1/4"	1 1/4"	10615K	23976	23977	12859/10514	(2) 23448	14159
M71-01	P	M71	1 1/4"	1 1/4"	10615K	23976	23977	12859/10514	(2) 23448	14159
P1012-01	P	P1014	1 1/4"	1 1/4"	10615K	19301	19300	12859	(2) 23448	19293
P1014	S		1 1/4"	1 1/4"	10615K	19301	19300	12859	(2) 23448	19293
P105-01	P	P105	1 1/4"	1 1/4"	10615K	10615K	19354	18652	(2) 08490	19308
P105	S		1 1/4"	1 1/4"	10615K	10615K	19354	18652	(2) 08490	19308
P109-01	P	P110	1 1/4"	1 1/4"	10615K	10615K	19354	18652	(2) 08490	19308
P110	S		1 1/4"	1 1/4"	10615K	10615K	19354	18652	(2) 08490	19308
P171	O	P176X	1 3/4"	1 3/4"	17000K	23973	23975	15955	(2) 15951	*
P1710-02	P	P1710A	W/O Port Elbow	W/O Port Elbow	17000K	23973	23975	23799/21776	24469 Shaft Bearing Assy†	
P1710A	S		W/O Port Elbow	W/O Port Elbow	17000K			23799/21776	24469 Shaft Bearing Assy†	
P1710X	O	P1710A	W/O Port Elbow	W/O Port Elbow	17000K	23973	23975	15955/21776	24469 Shaft Bearing Assy†	
P1711	O	P1719X	W/O Port Elbow	W/O Port Elbow	17000K	23972	23974	15955/19674	(2) 15951	19345
P1712	O	P1716X	1 3/4"	1 3/4"	17000K	23972	23974	15955/19674	(2) 15951	16046
P1716B-01	P	P1716X	2"	1 3/4"	17000K	23972	23974	15955/19674	24470 Shaft Bearing Assy†	
P1716B-02	P	P1716X	2"	1 3/4"	17000K	23972	23974	23799/19674	24470 Shaft Bearing Assy†	
P1716X	S		2"	1 3/4"	17000K	23972	23974	15955/19674	24470 Shaft Bearing Assy†	
P1719-01	P	P1719X	W/O Port Elbow	W/O Port Elbow	17000K	23972	23974	15955/19674	(2) 15951	19345
P1719F-01	O	P1719X	2"	2"	17000K	23972	23974	15955/19674	(2) 15951	19345
P1719X	S		W/O Port Elbow	W/O Port Elbow	17000K	23972	23974	15955/19674	(2) 15951	19345
P172	O	P1710A	1 3/4"	1 3/4"	17000K	23973	23975	15955/15950	(2) 15951	19620
P1722B-01	P	P1722X	2"	1 3/4"	17000K	23972	23974	15955/19674	24470 Shaft Bearing Assy†	

† Assembly includes bearing pressed onto the shaft along with the appropriate spacers, washers and retaining rings.



# Other OEM and General Service Pumps

CAM O-RING	GASKET /	BUSHING	BODY SCREW	CAM	COVER	HOUSING PLATE	WEAR	KEY	PIN	SLINGER ADAPT	HUB/ RING	RETAINING	PULLEY / GEAR
15883	12231/12855		12227	10515		12303	12856	04432/12622				(3) 4258/4259 (2)	
10929	(2) 12231	6333	22141	10515	22140	21150	22142	4432	(4) 21056			(3) 4258/4259 (2)	
10929	(2) 12231	6333	22141	10515	22140	21150	22142	4432	(4) 21056			(3) 4258/4259 (2)	
10929	(2) 12231	6333	23798	10515	22140	21150	22142	4432	(4) 21056			04258/05126/06837	
18663	12231/12855		12227	10195		18451	12856	04432/18576				(3) 4258/4259 (2)	
	12231		23231		21173	23230	22836	4432				(2) 4258/4259 (1)	23870
	12231		23231		21173	23230	22836	4432				(3) 4258/4259 (1)	23870
	12231		23231		21173	23230	22836	4432				(2) 4258/4259 (1)	
	12231		23231		21173	23230	22836	4432				(2) 4258/4259 (1)	23870
18314	12231/12855		12227	12857		17684	12856	4432				(3) 4258/4259 (2)	
18314			12227	12857		19880	12856	4432				(2) 4258/4259 (3)	
19829	19879		19827		19837	19828	19836			19868		(2) 19762/19867 (1)	
(2) 21533	(2) 21561		*		19837	21565	19836		21566	19868		(2) 19762/19867 (1)	
(2) 21106	(2) 21561		22125		19837	21829	19836		21566	19868		(2) 19762/19867 (1)	
(2) 21533	(2) 21561		21986		19837	21829	19836		21566	19868		(2) 19762/19867 (1)	
(2) 21533	(2) 21561		21986		19837	21829	19836		21566	19868		(2) 19762/19867 (1)	
(2) 21106	(2) 21561		21827		19837	21829	19836		21566	19868		(2) 19762/19867 (1)	
(2) 21106	(2) 21561		21827		19837	21829	19836		21566	19868		(2) 19762/19867 (1)	
(2) 21533	(2) 21561		22412		19837	22762	19836	22791	21566	19868		(2) 19762/19867 (1)	22789
(2) 21533	(2) 21561		22412		19837	22762	19836	22791	21566	19868		(2) 19762/19867 (1)	22789
(2) 21533	(2) 21561		23916		19837	22762	19836	22791	21566	19868		(2) 19762/19867 (1)	22789
(2) 21106	1720-0212		23396		19837	23523	19836		21566	19868		(2) 19762/19867 (1)	
(2) 21106	1720-0212		23396		19837	23523	19836		21566	19868		(2) 19762/19867 (1)	
(2) 21106	1720-0212		24174		19837	23523	19836		21566	19868		(2) 19762/19867 (1)	
15883	12231/12855		12227	10515		11903	12856	04432/12622				(3) 4258/4259 (2)	
22453	23111		23056		23113	23057	23112		21566			1810-0012/23091/23115	23181
24160	23111		23056		23113	24229	23112		21566			1810-0012/23091/23115	23181
24160	23111		23919		23113	24159	23112		21566			1810-0012/23091/23115	23181
24075	19879		24102	19714	24074	24072	24073			24079		(2) 19762/19867 (1)	24083
24075	19879		24102	19714	24074	24072	24073			24079		(2) 19762/19867 (1)	24083
24075	19879		24102	19714	24074	24072	24073			24079		(2) 19762/19867 (1)	24083
10944	12231/12855		12227	10515		12228	12856	04432/12622				(3) 4258/4259 (2)	
10944	12231/12855		12227	10515		12907	12856	04432/12622				(3) 4258/4259 (2)	
	21303/22770		22685		22767	22688	22768	10093				4258/4259	
10929	12231/12855		18075	10515		18154	12856	04432/12622				(3) 4258/4259 (2)	
	23447		23354		23366	24100						(1) 23325/23443 (1)	
	23447		23354		23366	24100						(1) 23325/23443 (1)	
	23447		23678		23366	24100						(1) 04258/04259 (1)	23680
18663	19964			10195		21862		13777				(2) 4258/4259	
18398	12231/12855		14160	10515		17684	12856	4432			18681	4258/14161/4259 (2)	14184
18398	12231/12855		14160	10515		17684	12856	4432			18681	4258/14161/4259 (2)	14184
18398	12231/12855		14160	10515		17684	12856	4432			19387	4258/14161/4259 (2)	14184
18398	12231/12855		19907	10515		17684	12856	4432			21700	(2) 4258/4259	19884
18398	12231/12855		19907	10515		17684	12856	4432			21700	(2) 4258/4259	19884
	23447		23354		23366	23352						23325/23443	
	23447		23678		23366	23352						04258/04259	23680
10944	12231/12855		14160	10515		12228	12856	4432			18681	4258/14161/4259 (2)	14184
10944	12231/12855		14160	10515		12228	12856	4432			18681	4258/14161/4259 (2)	14184
10944	19251		19294	10515	23946		19295	4432			97176	(2) 4258/4259 (1)	
10944	12231			10515	21120	24107	19295	4432			97176	(2) 4258/4259 (1)	
10944	12231			10515	23912	21378		4432				5126/6837	
10944	12231			10515	21120	21378		4432				5126/6837	
10944	12231			10515	23912	23791		4432			23770	05126/06837	
10944	12231			10515	21120	23791		4432			23770	05126/06837	
18271	15945		19673	18742	*	*	18441	15948				(3) 15952/15942(1)	
18271	15945		19714	18742		19683	18441	19667				(3) 15952/15942 (1)	
18271	15945		19714	18742		24161	24162	19667		24156		(3) 15952/15942 (1)	
18271	15945		19714	18742		19683	18441	19667				(3) 15952/15942 (1)	
18271	15945		19714	18742	*	*	18441	19209			*	(3) 15952	
18271	15945		19673	18742		18385	18441	19209			*	(3) 15952/15942 (1)	14184
18271	21570/15945		19714	18742		19630	18441	19667			19727	(3) 15952	19885
18271	21570/15945		19714	18742		19630	18441	19667			19727	(3) 15952	19885
18271	21570/15945		19714	18742		19630	18441	19667			19727	(3) 15952	19885
18271	15945		19714	18742		19732	18441	19667		19712	19700	(3) 15952	
18271	15945		19714	18742		19732	18441	19667		19712	19700	(3) 15952	
18271	15945		19714	18742		19732	18441	19667		19712	19700	(3) 15952	
18271	15945		19673	18742	*	*	18441	15948				(3) 15952/15942 (1)	
18271	21570/15945		19714	18742		19630	18441	19667			19955	(3) 15952	19885

SHERWOOD NUMBER	PUMP AVAIL	REPLACEMENT PUMP	PORTS		IMPELLER KIT	MINOR REPAIR KIT	MAJOR REPAIR KIT	SEAL & SEAT/ LIP SEAL	BEARING ASSEMBLY	SHAFT
			INLET	OUTLET						
P1722B-02	P	P1722X	2"	1 3/4"	17000K	23972	23974	23799/19674	24470 Shaft Bearing Assy†	
P1722X	S		2"	1 3/4"	17000K	23972	23974	15955/19674	24470 Shaft Bearing Assy†	
P1726	P	P1710A	W/O Port Elbow	W/O Port Elbow	17000K	23973	23975	15955/21776	24469 Shaft Bearing Assy†	
P1726X	O	P1710A	W/O Port Elbow	W/O Port Elbow	17000K	23973	23975	15955/21776	24469 Shaft Bearing Assy†	
P1726TC-02	P	P1726TC	W/O Port Elbow	W/O Port Elbow	17000K			23799/21776	24469 Shaft Bearing Assy†	
P1726TC	S		W/O Port Elbow	W/O Port Elbow	17000K			23799/21776	24469 Shaft Bearing Assy†	
P1727A	S		W/O Port Elbow	W/O Port Elbow	17000K			23799/24250	24470 Shaft Bearing Assy†	
P1727FB-01	P	P1727A	2"	1 3/4"	17000K	23972	23974	15955/19674	24470 Shaft Bearing Assy†	
P1727FB-02	P	P1727A	2"	1 3/4"	17000K	23972	23974	23799/19674	24470 Shaft Bearing Assy†	
P1727X	O	P1727A	W/O Port Elbow	W/O Port Elbow	17000K	23972	23974	15955/19674	24470 Shaft Bearing Assy†	
P173	O	P1722X	1 3/4"	1 3/4"	17000K	23972	23974	15955/19674	(2) 15951	16046
P1730A	S		W/O Port Elbow	W/O Port Elbow	17000K			23799/24250	24470 Shaft Bearing Assy†	
P1730-02	P	P1730A	W/O Port Elbow	W/O Port Elbow	17000K	23972	23974	23799/19674	24470 Shaft Bearing Assy†	
P1730F-01	P	P1730A	2"	1 3/4"	17000K	23972	23974	15955/19674	24470 Shaft Bearing Assy†	
P1730F-02	P	P1730A	2"	1 3/4"	17000K	23972	23974	23799/19674	24470 Shaft Bearing Assy†	
P1730X	O	P1730A	W/O Port Elbow	W/O Port Elbow	17000K	23972	23974	15955/19674	24470 Shaft Bearing Assy†	
P1731F-01	P	P1730A	2"	1 3/4"	17000K	23972	23974	15955/19674	24470 Shaft Bearing Assy†	
P1731F-02	P	P1730A	2"	1 3/4"	17000K	23972	23974	23799/19674	24470 Shaft Bearing Assy†	
P1732A	S		W/O Port Elbow	W/O Port Elbow	17000K			23799/21776	24469 Shaft Bearing Assy†	
P1732-02	P	P1732A	W/O Port Elbow	W/O Port Elbow	17000K	23973	23975	23799/21776	24469 Shaft Bearing Assy†	
P1732X	O	P1732A	W/O Port Elbow	W/O Port Elbow	17000K	23973	23975	23799/21776	24469 Shaft Bearing Assy†	
P1733F-01	P	P1733X	2"	2"	17000K	23972	23974	15955/19674	(2) 15951	24015
P1733X	S		W/O Port Elbow	W/O Port Elbow	17000K	23972	23974	15955/19674	(2) 15951	24015
P176-02	P	P176X	1 1/2"NPT	1 3/4"	17000K	23973	23975	23799	(2) 15951	19620
P176X	S		1 1/2"NPT	1 3/4"	17000K	23973	23975	15955	(2) 15951	19620
P2701-01	P	P2701X	2"	2"	27000K			23799	24306 Shaft Bearing Assy†	
P2702-01	P	P2701X	W/O Port Elbow	W/O Port Elbow	27000K			23799	24306 Shaft Bearing Assy†	
P2701X	S		W/O Port Elbow	W/O Port Elbow	27000K			23799	(2) 15951	24147
R102	S		1" NPT	1" NPT	10615K	10999	11068	10927	4257	18502
R30G	S		1/2" NPT	1/2" NPT	10077K	10996	24025	11367	4306	10289
R50G	S		3/4" NPT	3/4" NPT	09959K	10997	12937	10927	4257	10175

† Assembly includes bearing pressed onto the shaft along with the appropriate spacers, washers and retaining rings.

CAM O-RING	GASKET /	BUSHING	BODY SCREW	CAM	COVER	HOUSING PLATE	WEAR	KEY	PIN	SLINGER ADAPT	HUB/ RING	RETAINING	PULLEY / GEAR
18271	21570/15945			19714	18742	19630	18441	19667			19955	(3) 15952	19885
18271	21570/15945			19714	18742	19630	18441	19667			19955	(3) 15952	19885
21318	15945			19714	18742	19683	18441	19667			19699	(3) 15952/15942 (1)	
21318	15945			19714	18742	19683	18441	19667			19699	(3) 15952/15942 (1)	
22821	15945			19714	22819	22820	22818	19667			19699	(3) 15952/15942 (1)	
22821	15945			19714	22819	22820	22818	19667			19699	(3) 15952/15942 (1)	
18271	21570/15945			19714	18742	24176	24162	19667		24156	21205	(3) 15952	19885
18271	21570/15945			19714	18742	21523	18441	19667			21205	(3) 15952	19885
18271	21570/15945			19714	18742	21523	18441	19667			21205	(3) 15952	19885
18271	21570/15945			19714	18742	21523	18441	19667			21205	(3) 15952	19885
18271	15945			10515	18742	18385	18441	19209			*	(3) 15952/15942 (1)	14184
18271	21570/15945			19714	18742	24176	24162	19667		24156	21985	(3) 15952	22495
18271	21570/15945			19714	18742	21523	18441	19667			21985	(3) 15952	22495
18271	21570/15945			19714	18742	21523	18441	19667			21985	(3) 15952	22495
18271	21570/15945			19714	18742	21523	18441	19667			21985	(3) 15952	22495
18271	21570/15945			19714	18742	21523	18441	19667			21985	(3) 15952	22495
18271	21570/15945			19714	18742	21523	18441	19667			21985	(3) 15952	22495
18271	21570/15945			19714	18742	21523	18441	19667			21985	(3) 15952	22495
21318	15945			19714	18742	24161	24162	19667		24156	19699	(3) 15952/15942 (1)	
21318	15945			19714	18742	19683	18441	19667			19699	(3) 15952/15942 (1)	
21318	15945			19714	18742	19683	18441	19667			19699	(3) 15952/15942 (1)	
18271	15945			19714	18742	19732	18441	19667			24016	(3) 15952	
18271	15945			19714	18742	19732	18441	19667			24016	(3) 15952	
18271	15945			10515	18742	19015	18441	19667				(3) 15952/15942(1)	
18271	15945			10515	18742	19015	18441	19667				(3) 15952/15942(1)	
18271	15945			19714	18742	24161	24162				24144	(2) 15952/15942 (1)	
18271	15945			19714	18742	24161	24162				24144	(2) 15952/15942 (1)	
18271	15945			19714	18742	24161	24162				24144	(2) 15952/15942 (1)	
10929	10931	6333	18501	10515	10182			(2)4432	(2) 1311			(3) 4258/4259	
10285	10197/10286	2075	10596	10195	10279	15103		10093	(2) 1311			4303/4304 (3)	
15883	10103/10171	6333	10176	9919	10094	15104		4432	(2) 1311			(3) 4258/4259	4258

# Sherwood Repair Kits

Kit #	For Model Numbers	Kits Include the Following												
		Bushing	Ball Bearing	Seal Assy	O-Ring/Gasket	Impeller	Cam	Wear Plate	Key	Cover Assy	Lip Seal	Retaining Rings	Washer	Shaft
<b>Minor Kits</b>														
09959K	R991, B06, G65				2	1								
10244	N10360GX	1	1	1	2	2								
10615K	P102, P105, P109, G1004, G1005, G1006, G1008				2	1								
10656	D75, D60, D65			1	2	2								
10996	R30G-1, E05, R30G			1	2	1			1			1		
10997	R10870G, R10930G, R50G			1	2	1			1			1		
10999	E35, C-03, F10, S11040G, B04, R10970G, RPBC, F95, R102			1	1	1			1			1		
11430	D05	1	1	1	1	1								
12981	H5				2	1					1			
19301	P101, P1012			1	1	1								
23972	P1712, P1716B, P173, P1722B, P1727FB, P1730F, P1731F, P1711, P1719, P1719F			1	1	1			1	1		1		
23973	P171, P176, P172, P1710, P1726, P1726TC, P1732			1	1	1			1	1		1		
23976	G3, G4, G5, G5-1, G7, G7B, G8, G26, G45-1, G45-2, G46, G50, G55-2, G56, G85, H-85, K90, L10, L10B, L80, L90, M71			1	2	1			1			3	1	
23979	G1, G2, G15, G20, G21, G22, G30-2, G30-2B, G95-1, G9901, G9902, G9903, H10, J70, K75, K75B			1	2	1			1			3	1	
23980	GC1, GC4, GC5, G157, G151, G155, G1503			1	2	1			1			3	1	
24004	G1804, G1806, G18061, G1808, G18081			1	2	1	2					1	1	
24005	G1810			1	2	1	2					1	1	
24023	G1805, G1807, G18071			1	2	1	2					1	1	
<b>Major Kits</b>														
11068	E35, C-03, F10, S11040G, B04, RPBC, R102	1	1	1	1	1	1		1			3		
12221	G65, F85			2	1	1					1			
12300	D60, D65	1	1	1	2	2	1							
12665	G1, G2, G15, G20, G21, G22, G30-2, G30-2B, G95-1, G9901, G9902, G9903, H10, J70, K75, K75B			2	1	2	1	1	1	1		5	1	
12937	R10870G, R50G	1	1	1	2	1	1		1			4		
12980	H5			1	1	1	1		1		1			
13366	H70	1			1	1	1		1		1	2		
18655	R991	1	1	1	1	1	1					4	1	
19300	P101, P1012			2	1	1	1					1		
19354	P102, P105, P109			2	2	1					1	1	1	
22014	G1004, G1005				1	1	1	1	1		1			
22276	G1006, G1008				1	1	1	1	1	1		5		
23234	G2201, G22011				1	1	1	1		1		1		
23256	G1503			2	2	1	1		1	1	1	3	1	
23974	P1712, P1716B, P173, P1722B, P1727FB, P1730F, P1731F, P1711, P1719, P1719F			2	1	1	1	1	1	1	1	1	3	3
23975	P171, P176, P172, P1710, P1726, P1726TC, P1732			2	1	1	1	1	1	1	1	1	3	3
23977	G3, G4, G5, G5-1, G7, G7B, G8, G26, G45-1, G45-2, G46, G50, G55-2, G56, G85, H-85, K90, L10, L10B, L80, L90, M71			2	1	2	1	1	1	1		5	1	
23981	GC1, GC4, GC5, G157, G151, G155			2	1	2	1	1	1	1		5	1	
24006	G1804, G1806, G18061				1	2	1	2	1		1	1	2	2
24007	G1808, G18081				1	2	1	2	1	1	1	1	2	4
24008	G1810				1	2	1	2	1		1	1	2	1
24024	G1805, G1807, G18071				1	2	1	2	1		1	1	2	2
24025	R30G-1, E05, R30G	1	1	1	2	1	1		1			4		

# 09959, 10615, and 15000 G Series Technical Guide

## Assembly/Disassembly Instructions

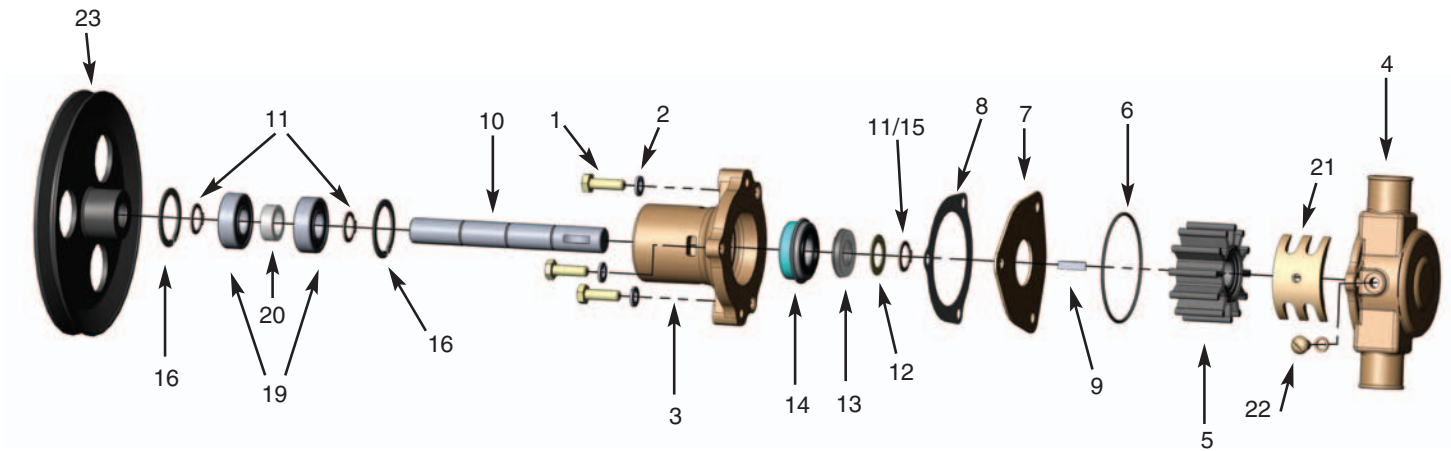

The following assembly/disassembly procedures apply to all G Series pumps. Deviations from pump to pump are primarily a result of different methods of drive and mounting.

### Disassembly:

- A. Remove the screws (1) and lockwashers (2) that hold the body (3) and housing (4) together.
- B. The housing assembly including the impeller (5) can be removed from the body assembly, along with the o-ring (6), spacer plate (7) and gasket (8).
- C. Remove the woodruff key (9) from the shaft (10). If the shaft is to be used again, and if it is put in a vise, always use lead over the jaws of the vise so that the shaft is not damaged.
- D. Remove the retaining ring (11 or 15) from the shaft (impeller end). The shoulder washer (12) and seat assembly (13) can now be removed.
- E. From the drive end of the pump (pulley end, hub end, shaft end), remove retaining ring, remove pin (17), remove woodruff key (18) and loosen setscrew if used. NOTE: If the pulley (23) or hub (24) is pressed on the shaft, it will be necessary to locate a support directly between the pump body and pulley or hub as close to the shaft as possible. Press the shaft out of the pulley or hub. Make sure the body is free and not supported.
- F. Remove the large internal retaining ring (16) from the body at the end of the bearing.
- G. Support the body, and press the shaft, bearings (19), spacer (20) and retaining rings (11) out through the bearing or pulley end of the body.
- H. The seal assembly (14) is pressed into the body. It can be removed by pushing a tool through the bearing end and up against the metal or back side of the seal. NOTE: On some pumps there is a spacer located between the pulley (hub) and bearing on the shaft. On other pumps, the bearings are positioned on the shaft with a retaining ring on each end. Support the bearings on the inner race, and push the shaft out of the bearings.

### Assembly:

- A. When assembling the cam (21), put Permatex #1 on the backside of the cam and the screw (22) that retains the cam. Wipe off any Permatex that gets into the impeller cavity.
- B. Assemble a retaining ring (11) on the shaft into the second groove from the impeller end. Push the ball bearing (19) over the shaft (10). Press on the inner race of the bearing. Push the bearing up against the retaining ring. Assemble a spacer and then the second ball bearing. Assemble the second retaining ring over the shaft and up against the ball bearing, if required.
- C. There is a large internal retaining ring (16) located in the body that provides a shoulder for the bearings (approximately 1.38" from the bearing end of the body). If it has been removed, it must be inserted at this time.
- D. Press the mechanical seal (14) into the body from the impeller end. Make sure that seal is pressed in square. A tool should be used to assure proper assembly.
- E. Push the bearing and shaft assembly into the body using care not to cock the bearing. A tool is recommended that will give you uniform pressure on the bearing outer race. Lock the bearing in place with the large internal retaining ring.

## 09959, 10615, and 15000 G Series Technical Guide *(continued)*

- F. Assemble the seat assembly (13), shoulder washer (12) and retaining ring (11 or 15) over the shaft from the impeller end. Locate the white ceramic surface against the seal – Do not damage (scratch) the white ceramic surface of the seat, or the seal and seat assembly might leak. Lubricate the rubber part of the seat and use a tool for ease of assembly.
- G. While supporting the shaft, press the pulley (23) or hub (24) onto the shaft. Secure pulley/hub with pin (17) or key (18) and retaining ring or setscrew as needed.
- H. Press the woodruff key (9) into the shaft. Make sure the stainless steel key is used at this location.
- I. Assemble the impeller (5) into the housing (4).
- J. Assemble the gasket (8) and spacer plate (7) on the body (3), and line up the screw holes. Replace the lockwashers (2) and tighten the screws (1).
- K. Make sure the o-ring (6) is properly located in the groove in the housing. A small dab of grease will help hold it in position until the housing to body screws are tightened.

### 09959 Chart

Sherwood #		G15	G21	G30-2B	G30-2	G9901	G9903	J70	K75B
Engine Manufacturer		Chris Craft		Chris Craft	Chris Craft	Volvo/OMC	Volvo/OMC	Commander	
Engine Model		350		350	350	6&8 Cyl	4 Cyl	302&351	
ITEM	QTY	16.80-18346	16.80-18346	3852398	3855079	CM1-10-610			
1	Screw	3	12857	12857	12857	12857	12857	12857	12857
2	Lockwasher	3	12710	12710	12710	12710	21757	21757	12710
3	Body	1	12324	12328	19784	12328	21153	21759	12328
4	Housing	1	12303	12303	12303	12303	21151	21151	12303
5	Impeller	1	9959	9959	9959	9959	9959	9959	9959
6	O-ring	1	12231	12231	12231	12231	12231	12231	12231
7	End Plate	1	12856	12856	12856	12856	12856	12856	12856
8	Gasket	1	12855	12855	12855	12855	12855	12855	12855
9	Key	1	4432	4432	4432	4432	4432	4432	4432
10	Shaft	1	12233	13363	12612	12612	13363	13363	13274
11	Retaining Ring (Ext)	2/3	4258	4258	4258	4258	4258	4258	4258
12	Washer	1	4264	4264	4264	4264	4264	4264	4264
13/14	Water Seal/Seat Assy	1	12859	12859	12859	12859	12859	12859	12859
15	Retaining Ring (Ext)	1	12305						
16	Retaining Ring (Int)	2	4259	4259	4259	4259	4259	4259	4259
17	Pin	1			12791	12791			
18	Key	1	12622					12622	
19	Ball Bearing	2	23448	23448	23448	23448	23448	23448	23448
20	Spacer	1	5133	5133	5133	5133	5133	5133	5133
21	Cam	1	15883	15883	15883	15883	15883	15883	15883
22	Cam Screw	1	10515	10515	10515	10515	10515	10515	10515
23	Drive Pulley or Gear	1	12323	19729			21154	21175	13429
24	Hub	1			12615	12615			13795
	Minor Repair Kit*		23979	23979	23979	23979	23979	23979	23979
	Major Repair Kit*		12665	12665	12665	12665	12665	12665	12665

\* See page 39 for the Preventative Maintenance Schedule and page 28 for the Contents of the Kits.

## 10615 Chart

Sherwood #		G5	G7	G7B	G45-1	G46	G50	G55-2	K90	L10B	M71	
Engine Manufacturer		Chrys.	Chrys.	Chrys.	Chris Craft	OMC	Chrys.		Isuzu			
Engine Model		318, 340	318, 360	318, 360	454	V8 Chevy	318, 340		4,6 Cyl Diesel			
ITEM	QTY	3675763	4142878	4142878	16.80-18347	985096	3619212		X-26-230-1023			
1	Screw	3	12857	12857	12857	12857	12857	12857	12857	12857	12857	
2	Lockwasher	3	12710	12710	12710	12710	12710	12710	12710	12710	12710	
3	Body	1	12227	12227	19789	12328	12328	12227	12328	12227	19948	14160
4	Housing	1	12228	12952	12952	12228	12952	12228	12907	12228	13899	12228
5	Impeller	1	10615	10615	10615	10615	10615	10615	10615	10615	10615	10615
6	O-ring	1	12231	12231	12231	12231	12231	12231	12231	12231	12231	12231
7	End Plate	1	12856	12856	12856	12856	12856	12856	12856	12856	12856	12856
8	Gasket	1	12855	12855	12855	12855	12855	12855	12855	12855	12855	12855
9	Key	1	4432	4432	4432	4432	4432	4432	4432	4432	4432	4432
10	Shaft	1	12233	13363	13363	12612	13363	12233	12596	12596	13363	14159
11	Retaining Ring (Ext)	2/3	4258	4258	4258	4258	4258	4258	4258	4258	4258	4258
12	Washer	1	4264	4264	4264	4264	4264	4264	4264	4264	4264	4264
13/14	Water Seal/Seat Assy	1	12859	12859	12859	12859	12859	12859	12859	12859	12859	12859
15	Retaining Ring (Ext)	1	12305				12305					
16	Retaining Ring (Int)	2	4259	4259	4259	4259	4259	4259	4259	4259	4259	4259
17	Pin	1	11541			12791		11541	9420			
18	Key	1	12622					12622				
19	Ball Bearing	2	23448	23448	23448	23448	23448	23448	23448	23448	23448	23448
20	Spacer	1	5133	5133	5133	5133	5133	5133	5133	5133	5133	5133
21	Cam	1	10944	10929	10929	10944	10929	10944	10944	10944	10929	10944
22	Cam Screw	1	10515	10515	10515	10515	10515	10515	10515	10515	10515	10515
23	Drive Pulley or Gear	1	12326	15055	15055		15048	12323		14992		14184
24	Hub	1				12615			12926		13795	
	Oil Seal	1										10514
	Minor Repair Kit*		23976	23976	23976	23976	23976	23976	23976	23976	23976	23976
	Major Repair Kit*		23977	23977	23977	23977	23977	23977	23977	23977	23977	23977

\* See page 39 for the Preventative Maintenance Schedule and page 28 for the Contents of the Kits.

## 15000 Chart

Sherwood #		GC1	GC4	GC5	G151	G155	G157	G1503	
Item	QTY								
1	Screw	3	12857	12857	12857	12857	12857	12857	
2	Lockwasher	3	12710	12710	12710	12710	12710	12710	
3	Body	1	14160	14160	19907	12227	12227	23231	
4	Housing	1	17684	17684	17684	17684	19880	17684	23230
5	Impeller	1	15000	15000	15000	15000	15000	15000	15000
6	O-ring	1	12231	12231	12231	12231	12231	12231	12231
7	End Plate	1	12856	12856	12856	12856	12856	12856	22836
8	Gasket	1	12855	12855	12855	12855	12855	12855	
9	Key	1	4432	4432	4432	4432	4432	4432	4432
10	Shaft	1	21069	21069	19843	19570	19570	21231	23228
11	Retaining Ring (Ext)	2/3	4258	4258	4258	4258	4258	4258	4258
12	Washer	1	4264	4264	4264	4264	4264	4264	4264
13/14	Water Seal/Seat Assy	1	12859	12859	12859	12859	12859	12859	12859/12966
15	Retaining Ring (Ext)	1	14161	14161					
16	Retaining Ring (Int)	2	4259	4259	4259	4259	4259	4259	4259
19	Ball Bearing	2	23448	23448	23448	23448	23448	23448	23448
20	Spacer	1	5133	5133	19906	5133	5133	5133	23229
21	Cam	1	18398	18398	18398	18314	18314	18314	
22	Cam Screw	1	10515	10515	10515	10515	10515	10515	
23	Drive Pulley or Gear	1	14184	14184	14184	15055	15055		23870
24	Hub	1						21232	
	Oil Seal	1	10514	10514	10514				12966
	Cover								21173
	Minor Repair Kit*		23980	23980	23980	23980	23980	23980	23980
	Major Repair Kit*		23981	23981	23981	23981	23981	23981	23256

\* See page 39 for the Preventative Maintenance Schedule and page 28 for the Contents of the Kits.

## R Series Technical Guide

### Assembly/Disassembly Instructions

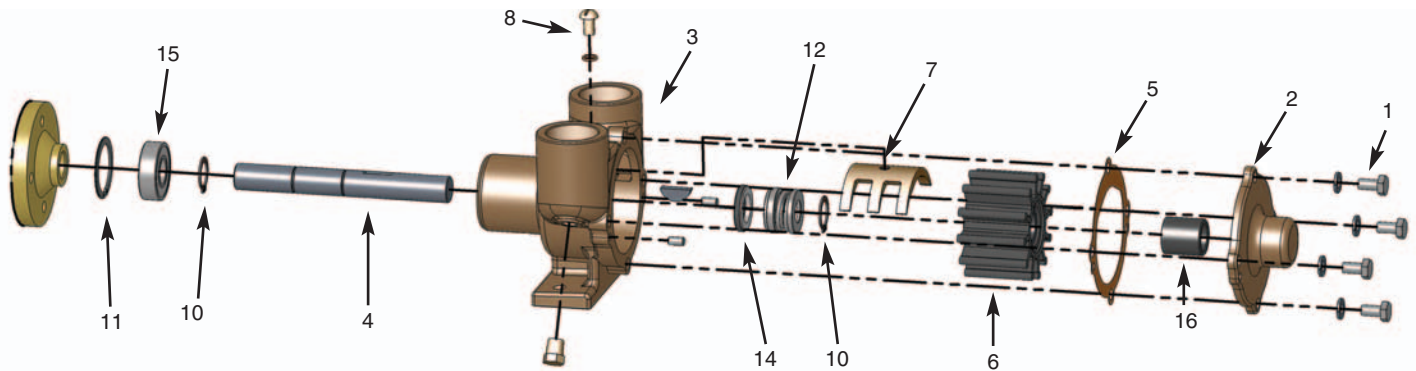

The following assembly/disassembly procedures apply to all R Series pumps. Deviations from pump to pump are primarily a result of different methods of drive and mounting. Pump numbers can be found on the tag or stamped on the pedestal base of the pump.

#### Disassembly:

- A. Remove the screws (1) and lockwashers that hold the cover to the body (3). Pull the cover and bushing assembly (2) off the drive shaft (4).
- B. Remove the vellum gasket (5). Sherwood recommends replacing the gasket each time the pump is assembled, however, if you plan to use the same gasket, it should be submerged in water until pump is reassembled. If gasket dries, it will shrink.
- C. The impeller (6) can now be removed by using pliers and grasping a vane on one side, then the other, alternating positions and gently pulling. Make sure you have a good grip on each vane so the pliers will not slip and damage the impeller.
- D. The cam (7) can be removed by removing the screw (8) that goes down through the top of the body between the intake and discharge ports.
- E. Remove the two screws (18) and lockwashers from the bearing housing (9) on the drive shaft end of the housing. This will allow you to remove the bearing housing, seal assembly, and shaft from the body.
- F. Remove the woodruff key from the shaft. If the shaft is to be used again and if it is put in a vise, always use lead over the jaws of the vise so that the shaft is not damaged.
- G. Remove the retaining ring (10) from the shaft at the seal end. The seal (12) can now be removed from the shaft. Note how the seal and seat assembly (14) are arranged so they can be properly reassembled.
- H. For the E35, support the hub and press the shaft and housing assembly off of the hub.
- I. By removing the large internal retaining ring (11) from the bearing housing, the bearing (15) and shaft can be pressed out of the bearing housing. Support the bearing housing, and press on the shaft from the impeller end.
- J. Pumps designed without separate bearing housings may require shaft removal from opposite end depending on housing design.
- K. The seat assembly (13) is pressed into the bearing housing and can be removed by pushing a tool through the bearing end and against the rubber or backside of the seat.

#### Assembly:

- A. When replacing the carbon bushing (16) in the cover, care should be taken not to crack the bushing. A tool that pilots on the inside diameter and presses uniformly against the end of the bushing is recommended.
- B. When assembling the cam (7), put Permatex #1 on back side of cam and the screw (8) that retains the cam. Wipe off any Permatex that gets into the impeller cavity.
- C. Assemble a retaining ring (10) on the shaft into the second groove from the drive shaft end. Push the ball bearing (15) over the shaft (4). Press on the inner race of the bearing. Push the bearing up against the retaining ring. Assemble the second snap ring (10) over the shaft and up against the ball bearing, from the flat shaft end.
- D. Push the bearing and shaft assembly into the bearing housing (9) using care not to cock the bearing. A tool is recommended that will give you uniform pressure on the bearing outer race. Lock the bearing in place with the large internal retaining ring.
- E. For pumps without a bearing housing, assemble the seat (13) into the counter bore in the housing (3) with the ceramic facing the impeller. Push the shaft and bearing assembly into the housing. Lock the bearings in place with retaining ring (11). While supporting the shaft, press the hub onto the shaft.



- F. From the opposite end (woodruff key end of the shaft), assemble the seat (13) over the shaft, rubber side first. Push it into the counter bore in the bearing housing. Do not damage (scratch) the white ceramic surface on the seat, or the seal and seat assembly might leak.
- G. Push the seal assembly (12) over the shaft and down against the seat. Do not damage the black carbon washer that rides against the ceramic.
- H. Assemble the third retaining ring (10) on the shaft. It will be necessary to compress the seal assembly to allow the retaining ring to enter the groove on the shaft.
- I. Press the woodruff key into the keyway in the shaft.
- J. Assemble the small gasket (17) over the pilot on the bearing housing and assemble the complete shaft, bearing, seal assembly, to the body. Use the two long screws for fastening the bearing housing to the body.
- K. Assemble the impeller (6) over the shaft (4). Line up the key in the shaft with the keyway in the impeller, and push the impeller into the body (3).
- L. Push the gasket (5) and cover (2) over the dowel pins, and attach the cover with the screws (1) and lockwashers.

Sherwood #		R30G	R30G-1	R10870G	R50G	R102	E35	
Port Size (NPT)		1/2"	1/2"	3/4"	3/4"	1"	1"	
Shaft Drive Description		Flat	Keyed	Keyed	Flat	Keyed	Pulley Hub	
ITEM	QTY							
1	Screw	4/6	12686	18999	01482	01482	01483	01483
2	Cover Assy	1	10281	10281	10096	10096	10183	10183
3	Body Assy	1	10597	10597	10177	10177	18503	11246
4	Shaft	1	10289	11854	10852	10175	18502	11744
5	Gasket, Cover	1	10286	10286	10103	10103	10931	10931
6	Impeller	1	10077	10077	09959	09959	10615	10615
7	Cam	1	10285	10285	10072	10072	10929	10929
8	Cam Screw	1	10195	10195	09919	09919	10515	10515
9	Bearing/Housing Assy	1	10198	10198	10172	10172		
10	Retaining Ring (Ext)	3	04304	04304	04258	04258	04258	04258
11	Retaining Ring (Int)	1	04303	04303	04259	04259	04259	04259
12	Seal	1	10522	10522	18743	18743	18743	18743
13	Seat	1	11361	11361	10926	10926	10926	10926
14	Seal/Seat Assy	1	11367	11367	10927	10927	10927	10927
15	Ball Bearing	1	04306	04306	04257	04257	04257	04257
16	Bushing	1	02075	02075	06333	06333	06333	06333
17	Gasket, Housing	1	10197	10197	10171	10171		
18	Screws	2	05437	05437	04265	04265		
	Key	1	10093	10093	04432	04432	04432	04432
	Dowel Pin	2	01311	01311	01311	01311	01311	01311
	Plug	1/2	00336	00336	00336	00336	00336	00336
	Hub	1						97176
	Minor Repair Kit*		10996	10996	10997	10997	10999	10999
	Major Repair Kit*		24025	24025	12937	12937	11068	11068

\* See page 39 for the Preventative Maintenance Schedule and page 28 for the Contents of the Kits.

## 17000 Series Technical Guide

### Assembly/Disassembly Instructions

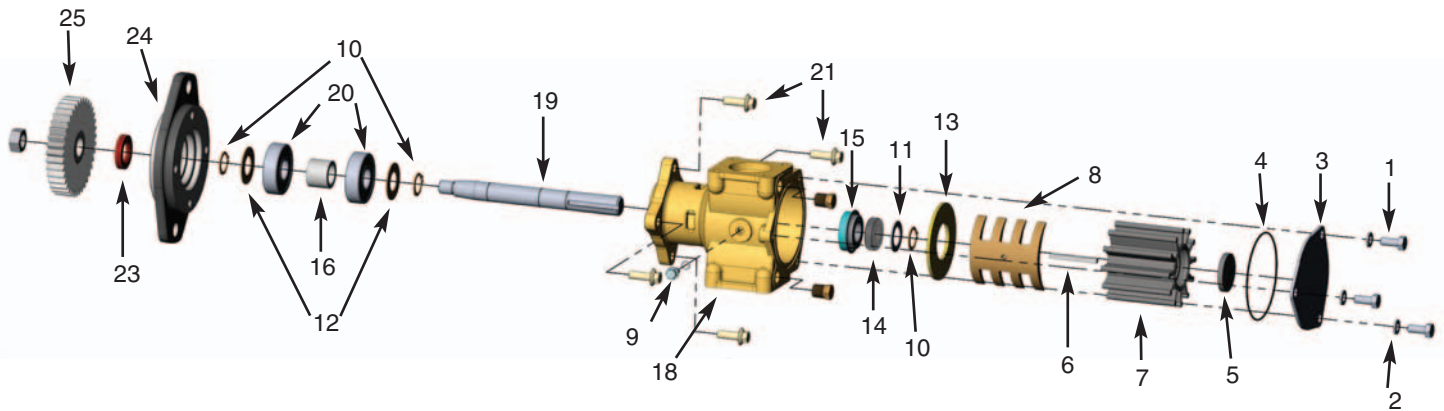

The following assembly/disassembly procedures apply to all 17000 Series pumps. Deviations from pump to pump are primarily a result of different methods of drive and mounting. Pump model numbers can be found stamped into the cover plate of the pump.

#### Disassembly:

- A. Remove the three bolts (1) and lock washers (2) from the pump cover (3). The cover and o-ring (4) are now free. The impeller end cap (5) can be pried off with a screwdriver. Normally, impellers (7) can be removed using two pair of pliers to grip two of the impeller's vanes on opposite sides of the impeller. A penetrating lubricant will help loosen a stuck impeller. Also, rotating the shaft by hand may help free the impeller. The 3/16" key (6) will also be removed at this time.
- B. Remove any pulleys or drive gears (25) from the drive shaft. For tapered shaft models (all models except P173 & P1719), it is necessary to remove the shaft nut and pull the gear or pulley with a puller. For models with pressed on gears (P173), two threaded holes are provided in the gear. An appropriate puller may be attached to these two holes to remove the gear from the shaft.
- C. Most models will be equipped with a flange adapter (24). The flange adapter is held to the pump body by two socket head cap screws (21), either 3/8" or 10mm, depending on the model. The screws are removed by using a hex socket wrench. More current models are mounted with four 8mm flange hex head bolts. The adapter is then removed. If the lip seal (23) in the adapter requires replacing, it can be pressed out at this time.
- D. The cam (8) and cam screw (9) are removed. The internal wear plate (13) will drop out. The retaining ring (10), washer (11) and seal seat (14) are then removed. External snap ring pliers are required.
- E. From the ball bearing end, the internal snap ring (17) must be removed on models P171 through P176. Later models have extended bearing assemblies and are held together by means of the flanged adapter. The bearing assembly (10,12,16,19 and 20) is pressed out of the body from the impeller end of the housing. The two external snap rings (10) are removed from the shaft (19) along with the bearing washers (12), permitting removal of bearings (20). The mechanical seal (15) may now be pressed from the bearing side of the housing (18).

#### Reassembly:

- A. Press mechanical seal (15) into housing (18). A small amount of Permatex or other sealant should be used to insure against leakage.
- B. Install external snap ring (10) on shaft (19). Next, place washer (12), bearing (20), bearing spacer (16), second bearing (20) and washer (12) and secure with the second external snap ring (10). The bearings will have to be pressed on from the pulley/gear end. Note that it is extremely important to properly align the bearings to the shaft prior to press, otherwise the possibility exists of galling the shaft in the area of the lip seal. This completes the bearing and shaft assembly.
- C. Press the bearing and shaft assembly into the housing (18). On older models, replace the internal snap ring (17). On new model pumps, the bearings will be flush to the end of the housing and will be retained with the flange adapter (24).
- D. On all older model pumps with mounting adapters, the lip seal (23) will have to be replaced prior to replacing the flange adapter (24). Care should be taken to insure proper alignment of the lip seal to the adapter and that the lip seal is uniformly pressed to prevent distortion. The adapter (24) may be reassembled to the pump housing (18) at this time. The use of Loctite #262 or equivalent is recommended on the adapter bolts.
- E. The ceramic seal and rubber cup (14) is now installed from the impeller end of the housing. Care must be taken to remove all burrs from the keyway to prevent cutting of the rubber cup. If possible, a half thickness key can be used to assist in assembly. In

pressing the ceramic and boot, a pusher should be used with a diameter only slightly greater than the shaft diameter, (.80"). Soapy water or a lubricant from a seal manufacturer may be used in assembly. Oil or grease must not be used as it will prevent the rubber cup from properly gripping the shaft. The seat and cup are pressed just beyond the external/snap ring groove. The seat should be inspected to insure that the cup did not become partially dislodged during the press procedure. The washer (11) and external snap ring (10) are then installed.

- F. The internal wear plate (13) is dropped in place, anti-rotation pin aligned with the cast slot in the bottom of the housing. The cam (8) is reinstalled and secured with the cam screw (9). Older model cam screws were sealed by means of a nylon washer requiring Permatex or other sealant to seal the cam screw. The cam screw should be inspected to insure that it does not protrude below the cam. This condition is possible if the nylon seal is badly deformed or if a substitute screw is used. Should the screw protrude beneath the cam, replace it with a new screw, or grind flush. Failure to do so will result in immediate impeller damage.
- G. At this time, if applicable, press on any gears (25) or pulleys. The shaft (19) must be securely supported from the impeller end and in line with the press. Failure to do so will result in either damaged bearings and/or a canted gear with excessive run out.
- H. Install the impeller (7) using a non-petroleum based lubricant such as silicone or soapy water. (The use of oils or grease will result in a damaged impeller). The impeller is installed using a twisting motion. Insure the impeller blades are bent in the same direction as upon removal. Once installed, rotate the shaft to align keyway and slide the key (6) in place. Then cover end with the rubber end plug (5).

Sherwood #		P176	P1710	P1716	P1719	P1722	P1726	P1727	P1730	P1731	P1732
ITEM	QTY										
1	Cap Screw	3	16029	19626	19626	19626	19626	19626	19626	19626	19626
2	Lockwasher	3	15944	15944	15944	15944	15944	21573	21573	21573	15944
3	Cover Plate	1	18742	18742	18742	18742	18742	18742	18742	18742	18742
4	O-ring	1	15945	15945	15945	15945	15945	15945	15945	15945	15945
5	Impeller Cap	1	19210	19210	19210	19210	19210	19210	19210	19210	19210
6	Key	1	19667	19667	19667	19667	19667	19667	19667	19667	19667
7	Impeller	1	17000	17000	17000	17000	17000	17000	17000	17000	17000
8	Cam	1	18271	18271	18271	18271	18271	18271	18271	18271	21318
9	Cam Screw	1	10515	19714	19714	19714	19714	19714	19714	19714	19714
10	Retaining Ring (Ext)	3	15952	15952	15952	15952	15952	15952	15952	15952	15952
11	Washer	1	15959	15959	15959	15959	15959	15959	15959	15959	15959
12	Washer	2	19614	19614	19614	19614	19614	19614	19614	19614	19614
13	Wear Plate-Pin Assy	1	18441	18441	18441	18441	18441	18441	18441	18441	18441
14/15	Water Seal/Seat Assy	1	15955	15955	15955	15955	15955	15955	15955	15955	23799
16	Spacer	1	15940	19707	19615	19615	19615	19707	19615	19615	19707
17	Retaining Ring (Int)	1	15942	15942				15942			15942
18	Housing	1	19015	19683	19630	19732	19630	19683	21523	21523	19683
19	Shaft	1	19620	19706	23866	19345	23866	19706	23866	23866	19706
20	Ball Bearing	2	15951	15951	15951	15951	15951	15951	15951	15951	15951
21	Adapter Bolts	4		19708	19708	19708	19708	19708	19708	19708	19708
23	Oil Lip Seal	1		21776	19674	19674	19674	21776	19674	19674	21776
24	Adapter	1		19699	19727	19700	19955	19699	21205	21985	19699
	Gear Assy	1			19885		19885		19885	22495	
	Cam Screw O-ring	1		19712	19712	19712	19712	19712	19712	19712	19712
	Gear Nut	1			19730		19730		19730	19730	
	Adapter Gasket	1			21570		21570		21570	21570	
	Flanged Port O-rings	2							21525	21525	
	Flanged Port Bolts	8								21484	
	Minor Repair Kit*		23973	23973	23972	23972	23972	23973	23972	23972	23973
	Major Repair Kit*		23975	23975	23974	23974	23974	23975	23974	23974	23975

\* See page 39 for the Preventative Maintenance Schedule and page 28 for the Contents of the Kits.

## 18000 Series Technical Guide

### Assembly/Disassembly Instructions

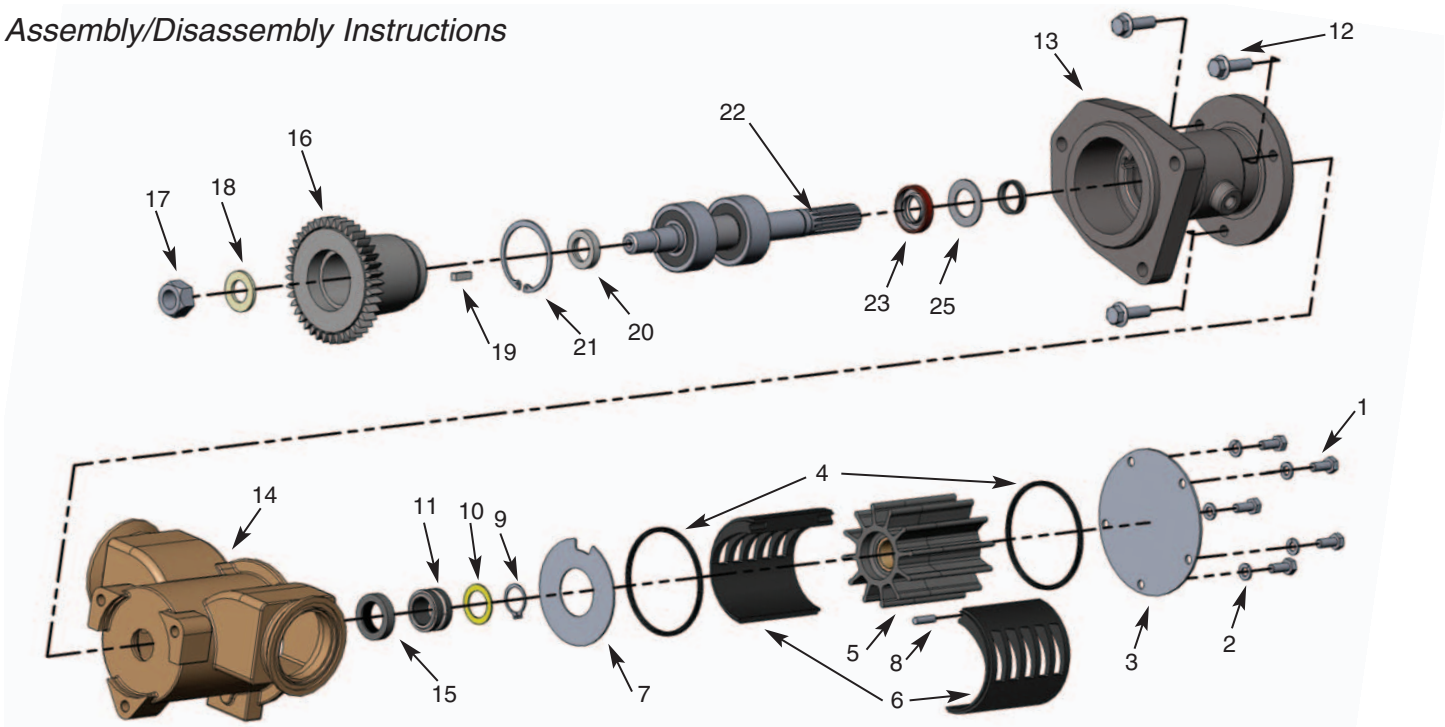

The following assembly/disassembly procedures apply to all 18000 Series pumps. Deviations from pump to pump are primarily a result of different methods of drive and mounting. Pump numbers can be found stamped into the cover plate of the pump.

### Disassembly:

- A. Remove the bolts (1) and lockwashers (2) from the cover (3).
- B. Remove the cover, quad rings (4), impeller (5), cam liner halves (6), and wearplate (7). Note the direction of the impeller blades to ensure proper replacement of the impeller during the assembly procedure. Caution: the pin (8) might fall out from its place between the cam liner halves.
- C. Using external snap ring pliers, remove the retaining ring (9) from the shaft.
- D. Slide the washer (10) and mechanical seal (11) off of the shaft.
- E. Remove the bolts (12) holding the body (13) to the housing (14).
- F. Slide the housing off of the shaft and body assembly.
- G. Press the seal seat (15) out of the housing.
- H. When applicable remove the drive gear assembly: while supporting the drive gear (16), remove the nut (17), nut washer (18), and key (19) from the shaft. Slide the gear off of the shaft and remove the thrust washer (20) behind the gear.
- I. Using internal snap ring pliers, remove the retaining ring (21) from the body. Remove the bearing shield (24) from the body.
- J. Press the bearing and shaft assembly (22) out of the body.
- K. Remove the lip seal (23) and washer (25) from the body.
- L. Inspect the shaft for grooving of the lip seal area and heavy fretting of the spline portion that drives the impeller. Inspect the bearings for loss of grease, corrosion, and rough rotation. If the shaft or bearings exhibit such a wear, replace the entire shaft and bearing assembly (22) listed on page 38.

**Warning:** Do not try to build the shaft and bearing assembly from the individual parts, but instead purchase the entire shaft and bearing assembly listed below. Due to extremely tight tolerances, special assembly procedures for this assembly must be followed to prevent galling of the shaft in the lip seal area.

### Assembly:

- A. Replace the washer (25) then press the lip seal (23) into the pump body (13) with the metal backing ring of the lip seal toward the housing (14) and away from the engine. Care should be taken to insure proper alignment of the lip seal to the pump body and that the lip seal is uniformly pressed to prevent distortion.

- B. Press the shaft and bearing assembly (22) into the pump body.
- C. Slide the bearing shield (24) into the pump body and against the inner bearing.
- D. Using internal snap ring pliers, install the retaining ring (21) into the body.
- E. Press the mechanical seal seat (15) into the housing with the white ceramic seal face or gray silicon carbide face toward the impeller. Lubricate the outside of the seat boot with a water soluble lubricant or soapy water for easier assembly. Oil or grease must not be used as it will prevent the rubber cup assembly from properly gripping the housing. The seat should be inspected to ensure that the cup did not become partially dislodged during the assembly procedure.
- F. Slide the housing over the shaft and body assembly. Fasten the three bolts (12) and torque them to 25 ft-lbs.
- G. When applicable replace the drive gear assembly. Slide the thrust washer (20) onto the outer bearing. Place the key (19) in the shaft, then slide the gear (16) on the shaft. Replace the washer (18) then tighten the nut (17) onto the shaft. While supporting the drive gear, torque the nut to 270 ft-lbs.
- H. Lubricate the inter rubber portion of the mechanical seal (11) with a water soluble lubricant or soapy water and slide the seal onto the shaft, with the carbon or silicon carbide portion of the mechanical seal toward the seal seat. Oil or grease must not be used as it will prevent the mechanical seal from properly gripping the shaft.
- I. Place the washer (10) onto the shaft and against the mechanical seal (see below to identify the proper washer) and then using external snap ring pliers, install the retaining ring (9) into the groove in the shaft to compress the mechanical seal.

### Seal Washer Selection

When replacing the mechanical seal, it is necessary to ensure the proper seal washer is used to avoid damage to the pump. It is recommended that all pumps be upgraded with the silicon carbide mechanical seal 23837, except for pump number G1810, which can only be fitted with the 23512 seal. Use the following to determine which washer to use:

- When using the silicon carbide mechanical seal 23837 for replacement, determine the proper spacer to use from the chart below. Silicon carbide is characterized by the charcoal gray colored seal and seat faces, as opposed to carbon on ceramic, which would be black on white.
- Exceptions to the chart
  - If the pump is to be fitted with the new shaft and bearing assembly listed on the chart on page 38 (24000, 24001, 24002, and 24003), use the 19866 washer. These shaft and bearing assemblies can only be used with the 23837 silicon carbide mechanical seals.
  - Replacement of the seal with the carbon on ceramic mechanical seal 19878 can only be performed on older units with the original shaft and bearing assemblies still in place. Use the 19866 spacer in such cases. Use of the 19878 seal with the current production units (G18061-01, G18071-01, and G18081-01) or with older units fitted with the new shaft and bearing assemblies will cause damage to the pump.

Pump Number	23837 Seal Spacer Number *
G1801	23840
G1804	23840
G1805	23840
G1806	23840
G18061-01	19866
G1807	23840
G18071-01	19866
G1808	23840
G18081-01	19866
G18082-01	19866
G1810	N/A

**Note: if the pump is fitted with a silicon carbide seal, it must be replaced with the 23837 silicon carbide seal to prevent damage.**

\* **Note:** the 19866 spacer is .060" thick and the 23840 is .260" thick.

- J. Install the wearplate (7) with the hole in the plate lined up with the slot in the housing. Install the quad ring (4) into the housing and on top of the wearplate.
- K. Create the cam assembly by connecting the cam halves (6) together and installing the pin (8) into the cam liner. A dab of grease can be used to hold the pin in place during installation. Place the cam assembly into the housing, ensuring that the pin aligns with the slot in the housing.
- L. Insert the impeller (5) in the housing using a twisting motion. Ensure that the impeller blades are bent in the same direction as upon removal (dependent on the pump model – see illustration on page 38 for details). For ease of installation apply a silicone lubricant to the impeller. Caution: DO NOT USE A PETROLEUM BASED LUBRICANT (petroleum product will cause damage to the impeller).

## 18000 Series Technical Guide *(continued)*



Vanes flipped to the left  
(viewed from cover).

**Models:** G1808, G18081-01,  
G18082-01 and G1810



Vanes flipped to the right  
(viewed from cover).

**Models:** G1801, G1804, G1805, G1806,  
G18061-01, G1807, and G18071-01

M. Insert the remaining quad ring (4) into the groove, install the cover (3) on the housing, and then fasten the lock-washers (2) and bolts (1) to 8 ft-lbs torque.

ITEM	Sherwood #	QTY	G1801	G1804	G1805	G1806	G18061-01	G1807	G18071-01	G1808	G18081-01	G1810
1	Cap Screw	5	19626	19626	19626	19626	19626	19626	19626	19626	19626	19626
2	Lockwasher	5	15944	15944	15944	15944	15944	15944	15944	15944	15944	15944
3	Cover Plate	1	19837	19837	19837	19837	19837	19837	19837	19837	19837	19837
4	Quad Rings	2	19879	21561	21561	21561	21561	21561	21561	21561	21561	21561
5	Impeller	1	18000	18000	18000	18000	18000	18000	18000	18000	18000	18000
6	Cam Liner Halves	2	19829	21533	21106	21533	21533	21106	21106	21533	21533	21106
7	Wear Plate	1	19836	19836	19836	19836	19836	19836	19836	19836	19836	19836
8	Pin	1		21566	21566	21566	21566	21566	21566	21566	21566	21566
9	Retaining Ring	2	19762	19762	19762	19762	19762	19762	19762	19762	19762	19762
10	Washer	1	19866	19866	19866	19866	19866	19866	19866	19866	19866	19866
11/15	Mechanical Seal Assy	1	19878	19878	19878	19878	23837	19878	23837	19878	23837	23512
12	Bolt	3	21172	21172	21172	21172	21172	21172	21172	21172	21172	21172
13	Body	1	19827	21476	21920	21986	21986	21827	21827	22412	22412	23396
14	Housing	1	19828	21565	21829	21829	21829	21829	21829	22762	22762	23523
16	Gear	1								22789	22789	
17	Nut	1								22790	22790	
18	Washer	1								22788	22788	
19	Key	1								22791	22791	
20	Thrust Washer	1								22779	22779	
21	Retaining Ring	1	19867	19867	19867	19867	19867	19867	19867	19867	19867	19867
22	Shaft and Bearing Assy*	1	24000	24001	24000	24001	24001	24001	24001	24002	24002	24003
23	Lip Seal	1	19869	19869	19869	19869	19869	19869	19869	23045	23045	19869
24	Bearing Shield	1										23425
25	Washer	1	19835	19835	19835	19835	19835	19835	19835	19835	19835	
	Minor Repair Kit**			24004	24023	24004	24004	24023	24023	24004	24004	24005
	Major Repair Kit**			24006	24024	24006	24006	24024	24024	24007	24007	24008

\* When using these Shaft and Bearing Assemblies, replace the seal with the silicon carbide mechanical seal 23837 only. Use of the 19878 mechanical seal with these Shaft and Bearing Assemblies may cause pump damage. See "Seal Washer Selection" on page 37.

\*\* See page 39 for the Preventative Maintenance Schedule and page 28 for the Contents of the Kits.

# Preventative Maintenance and Inspection

Maintenance Schedule	Pleasure Boating (Low Hours)		Commercial/Fishing Use (High Hours)	
	Light Duty	Severe Duty (High RPM, Silt or Sand)	Heavy Duty	Severe Duty (High RPM, Silt or Sand)
Impeller Kit	Every year	6 - 12 months	6 - 12 months	3 - 6 months
Minor Kit	2 years	Every year	Every year	6 months
Major Kit	4 years	2 years	2 years	Every year

\* See pages 16-27 for Repair Kit Part Numbers.

## Recommended inspection to be performed at any service interval:

- Impeller . . . . . Inspect for cracks or tears. Also, inspect for excessive abrasion of vane ends. Replace annually, or if any of the conditions exist, as in the picture below.\*
- Wear Plate . . . . . Inspect for wear, flatness, and pin for fatigue. Replace at major (minor and major for 17000 series) pump rebuild or if wear is evident to maintain pump flow and suction performance.
- Cam . . . . . Replace at major pump rebuild or if pitting/wear is evident.
- Cover . . . . . Replace at major pump rebuild or if wear exists to maintain pump flow and suction performance.
- Mechanical Seal . . . . Replace at minor and major pump rebuild or if leaking.
- Lip Seal . . . . . Replace at major (minor and major for 17000 and G series) pump rebuild or if leaking.
- Shaft . . . . . Inspect for wear in area of lip seal and rubber impeller. Grooving of lip seal area or heavy fretting of the impeller end shaft will require shaft replacement.
- Bearing . . . . . Inspect for loss of grease, corrosion or rough rotation. Replace at major pump rebuild (as for 18000 series, the entire shaft and bearing assembly, see page 38).

\* See maintenance schedule above.

## Sherwood Tech Tips

- Store impeller in dark, cool place
- Use non-petroleum lubricant to help install impeller
- Inspect impeller blades for indicated signs of wear and replace annually or if any of these conditions exist

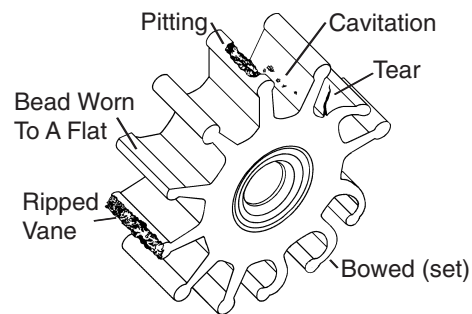

*The #1 Reason for Premature Engine Wear Is Overheating. To Maintain Engine Performance, Insist Upon GENUINE Sherwood Products.*

*Please visit us at [www.sherwoodpumps.com](http://www.sherwoodpumps.com)*



**Pentair Water**

**MARINE PRODUCTS GROUP**

375 Fifth Avenue NW • New Brighton, MN 55112-3288  
Phone: (651) 766-6300 • 800-471-0460 • Fax: 800-672-7023

**[www.hypropumps.com](http://www.hypropumps.com) [www.sherwoodpumps.com](http://www.sherwoodpumps.com)**