

**NEW  
DESIGN**

# WESTERBEKE 40a

**A NEW VERSION OF THE STANDARD WESTERBEKE 40**

NOTE: The 40a will fit Westerbeke's 4-107, 4-99, and 4-108 engine beds.

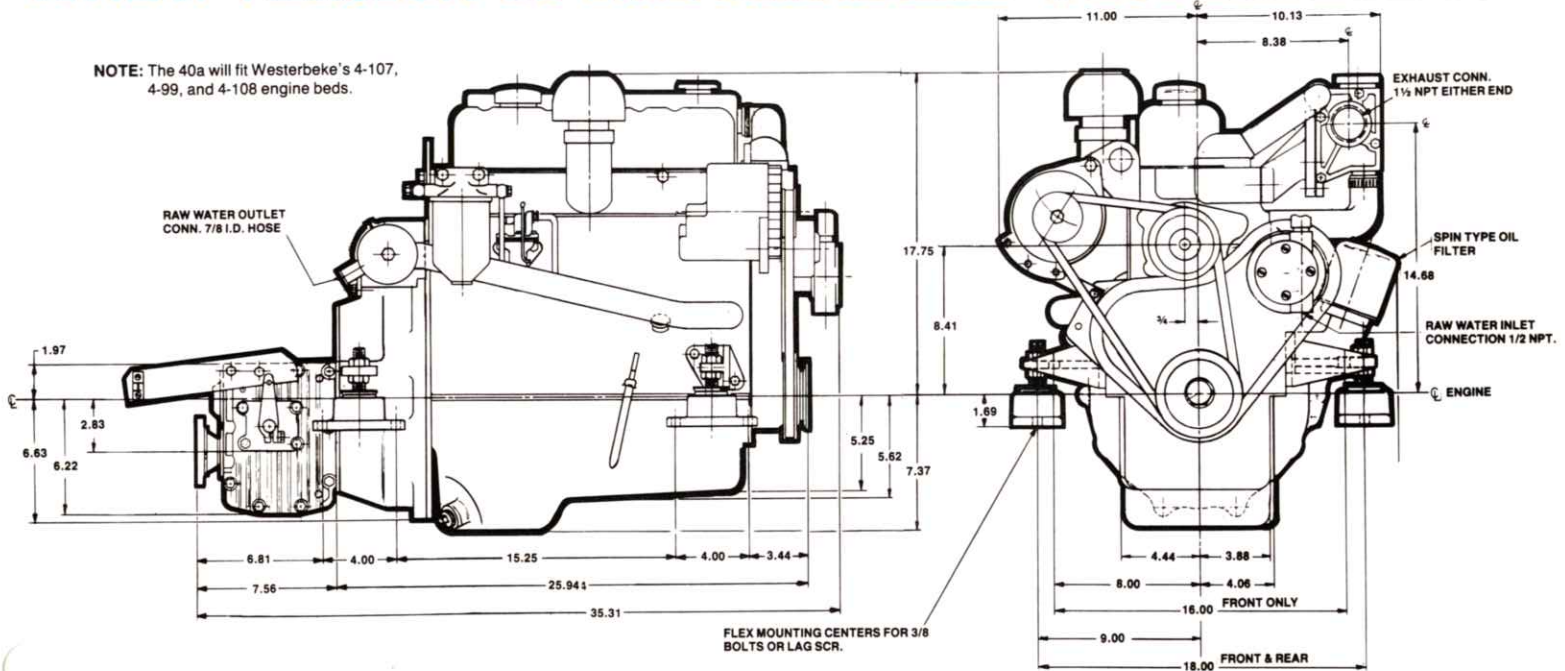

**Westerbeke's engineers have re-designed and modernized this tough reliable diesel into a smoother, cooler running, Marine Engine.**

## STANDARD EQUIPMENT

- Oversized heat exchanger
- Coolant recovery tank
- Throttle and shift control brackets
- 12 volt 51 amp alternator
- Engine tested with standard short profile 2:1 transmission
- Adjustable flex isolator engine mounts (see drawing)
- Fresh water cooling system
- Engine pre-wired with single 8 pin connector
- Transmission cooler
- Operator's manual

## OPTIONAL EQUIPMENT

- 45° water injected exhaust elbow
- Front exhaust outlet for Vee Drives
- Lube oil drain hose
- A wide variety of manual & hydraulic transmissions
- Flow control for maximum production of domestic hot water
- Remote mounting lube filters
- Low oil-pressure and high water temperature alarms
- Alternator output splitter
- Sea water intake strainer
- Hydro-Hush B waterlift exhaust silencer
- Various adapting connectors and couplings from which given a supply of 1 7/8" I.D. Exhaust Hose a complete exhaust system can be assembled.
- Engine oil cooler
- Starting aid system

## SPECIFICATIONS

Engine Type	Four cylinders in line, four cycle fresh water cooled diesel
Displacement	107 cu. in. Bore 3.125", Stroke 3.5"
Power	37 hp at 3000 rpm
Compression Ratio	22:1
Weight	474 lbs. basic engine.
Fuel Injection Equipment	Distributor type fuel pump with mechanical governor and pintle type injectors
Cylinder Block	One-piece iron alloy casting with replaceable liners
Cylinder Head	One-piece iron alloy casting with renewable valve guides
Crankshaft	Chrome molybdenum steel forging
Main Bearings	Three, replaceable, thin wall, lead bronze lined
Camshaft	High duty cast iron
Pistons	High silicon aluminum alloy
Connecting Rods	Drop forged steel
Lubrication	Eccentric lube oil pump, camshaft driven. Full flow spin-on lube oil filter
Mounting	Flexible mounts, 18" centers
Exhaust Manifold	Fresh water cooled, front or rear exhaust
Cooling System	Closed circuit fresh water system.
Fresh and raw water pumps, engine-mounted w/recovery tank	
Angle of Installation	17° maximum
Electrical System	12 volt negative ground system with 51 amp alternator standard



**WESTERBEKE**

AVON INDUSTRIAL PARK, AVON, MA 02322 • TEL: (617) 588-7700  
TELEX: 92-4444 • FAX: (617) 559-9323 • CABLE: WESTCORP

