

XINTEX[®] S-2

PROPANE/CNG MONITOR and CONTROL OWNERS INSTALLATION MANUAL



WARNING

This device is meant to serve as a supplemental warning system. IT IS NOT meant to replace standard safety practices which should be carried out around explosive gases (i.e., inspect engine compartment, check for loose fuel fittings, smell for gasoline fumes, etc.)

XINTEX, Manufactured exclusively by Detects, Inc.

P.O. Box 152, Grand Rapids, MI 49501-0152
Shipping: 100 Commerce Ave., S.W., Grand Rapids, MI 49503
Phone 616-235-2360 FAX: 616-454-8256

Detects, Inc., Subsidiary of Convenience Marine Products, Inc.

NOTE

XINTEX PRODUCTS WILL NOT FUNCTION RELIABLY, AND MAY FAIL TO FUNCTION AT ALL, UNLESS THE INSTALLATION, OPERATION, AND MAINTENANCE INSTRUCTIONS DESCRIBED IN THIS MANUAL ARE FULLY COMPLIED WITH AND STRICTLY FOLLOWED. FAILURE TO COMPLY WITH THESE INSTRUCTIONS WILL ALSO VOID YOUR WARRANTY.

1. INTRODUCTION

Your XINTEX™ S-2 gas vapor detection system is a state-of-the-art monitoring and control system for Liquid Petroleum Gas (LPG or propane), Compressed Natural Gas (CNG) and/or gasoline. This device has the capability of sensing leaks or spillage of these gases and controlling an electric solenoid valve in the supply line. Under normal operating conditions the S-2 allows you to manually control a solenoid valve while monitoring LPG/CNG and/or gasoline levels. In the event a sensor detects a leak the S-2 closes the valve and alarms with a beeping siren and a light indicating the sensor has detected fumes. It then prevents the valve from being turned on until the problem is cleared.

2. INSTALLATION

The S-2 is packaged with the following components. Please check to be sure that you have everything needed for your installation.

- 1 - Display Module
- 1 - Snap-on Bezel
- 4 ea. Mounting Screws
- 1 - Terminal Block
- 1 - Solenoid Valve SV-1
- 1 - Propane Sensor (Black)
- 1 - Sensor Simulator

Figure 1 illustrates these components. If you find a discrepancy in the contents, contact your Dealer or Detects, Inc. for immediate replacement.

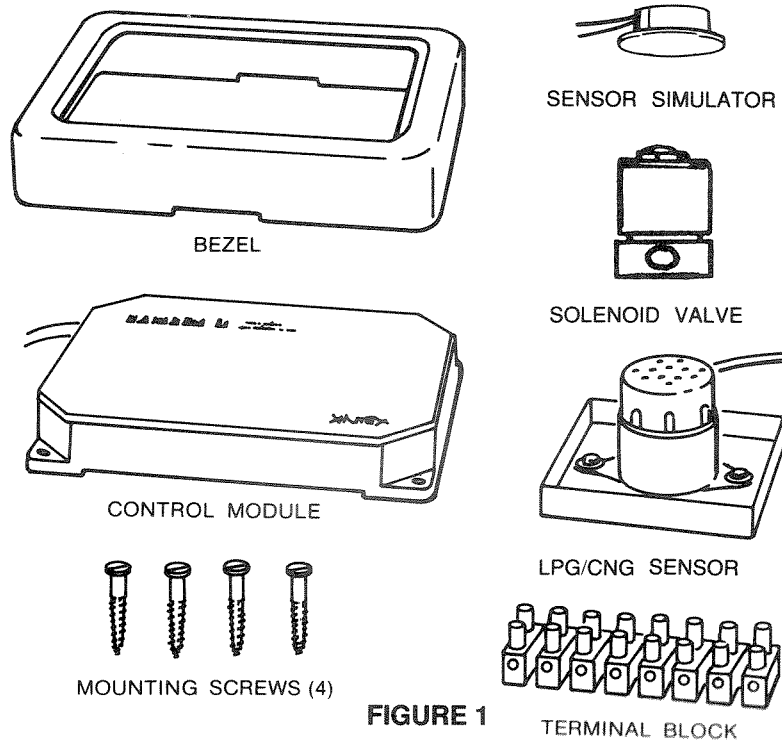

FIGURE 1

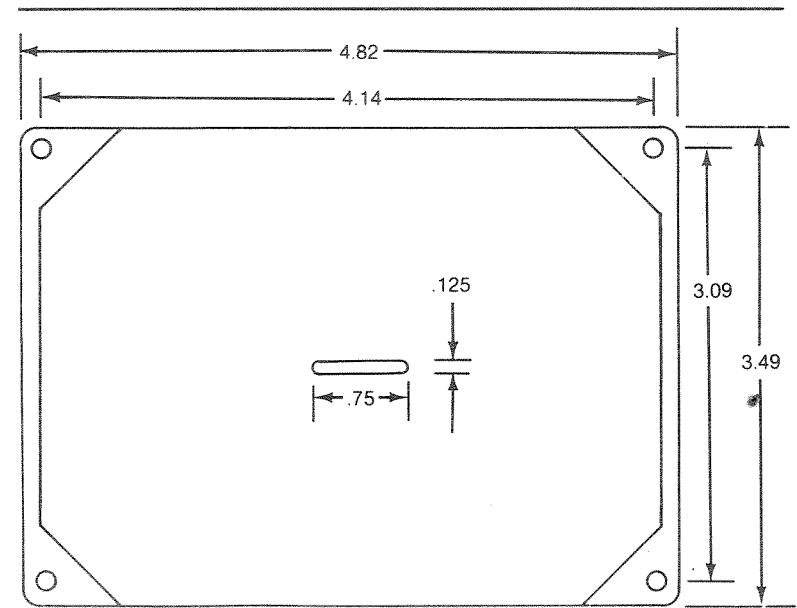

FIGURE 2

DISPLAY MODULE

The S-2 should be mounted in a convenient location such that the visual indicators may be seen easily. To mount the control module, you must first remove the snap-on bezel if it is not already off. This can be accomplished by inserting a small flat blade screwdriver into the slot on either side of the module and carefully prying up until the bezel is loosened. With the bezel removed you may mount the unit using the dimensions shown in Figure 2 or by using the housing itself as a template. The four enclosed wood screws will hold the module from the mounting holes in the corners of the case. The flat ribbon cable may optionally pass through the wall or bulkhead and run down the far side or it may lay flat against the wall or bulkhead and run down the near side. For installations that pass through the wall or bulkhead, #6 flat head machine screws may be used with a corresponding back nut and washer instead of the wood screws.

TERMINAL BLOCK

The enclosed terminal block may be installed out of sight where easy access to the connections is possible. All connections such as power, sensor, and valve connections are shown in Figure 3 and the wire functions are listed in Table 1.

RIBBON CABLE	FUNCTION
Brown	Power Ground
Red	Power +12 Volts
Orange	VALVE Control
Yellow	Sensor 1 Signal (Sensor 1 Green)
Green	Sensor 1 and 2 Low (Sensor 1 and 2 Black)
Blue	Sensor 1 and 2 High (Sensor 1 and 2 Red)
Violet	Sensor 2 Signal (Sensor 2 Green)
Gray	Remote Horn

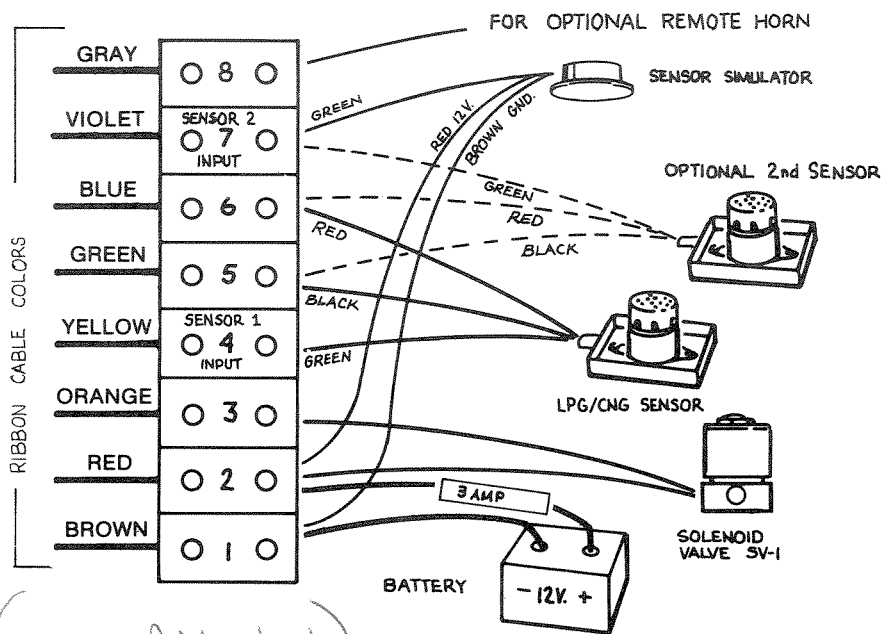

FIGURE 3

SENSOR SIMULATOR

The Xintex Vapor Detection System you have purchased comes with 2-channel monitoring capability, 1 Propane/CNG Sensor and 1 Sensor Simulator. The Propane/CNG Sensor connects to "Sensor 1" input, and the Sensor Simulator connects to "Sensor 2" input. (See Figure 3.) NOTE: The Black and White wires on the Sensor Simulator are not used in this installation and should be taped together and left unconnected.

If an optional second sensor is installed initially, do not use the sensor simulator. If the second sensor is installed later, remove the sensor simulator and follow the wiring instructions for second sensor indicated in Figure 3.

SENSOR LOCATIONS

BECAUSE THE S-2 IS DESIGNED TO DETECT PROPANE/CNG AS WELL AS GASOLINE VAPORS, SPECIAL ATTENTION SHOULD BE PAID TO SENSOR LOCATION. MOUNT EACH TYPE OF SENSOR PER APPLICABLE INSTRUCTIONS.

PROPANE SENSORS:

Propane is heavier than air and will settle downward as it disperses. A PROPANE (BLACK) SENSOR SHOULD BE INSTALLED LOW, AND NEAR THE BACK OF THE APPLIANCE. The sensor should NOT be exposed to high heat or direct heat, but they should be as close as possible to potential sources of gas leaks such as inlet pipes, valve or pipe connections.

CNG is lighter than air and rises as it disperses. A PROPANE/CNG (Black) SENSOR SHOULD BE INSTALLED ABOUT 9" BELOW THE CEILING FOR CNG APPLICATIONS. The sensors should be close to the appliance, but should not be located directly above a stove since some cooking vapors may trigger the alarm.

GASOLINE SENSORS:

Gasoline vapors are heavier than air, and tend to accumulate in the lowest part of the bilge. GASOLINE (Brown) SENSOR, SHOULD BE LOCATED IN THE BILGE AREA JUST ABOVE THE "SLOSH HEIGHT". Mount the sensor on a post, bulkhead, or engine stringer in such a way that oily bilge water cannot poison the sensor. Do not install sensor in a location close to manifold or exhaust system, as the high heat radiation will damage the sensor.

Voltage and Current Specifications

Voltage:	+12 to +15 Volts D.C. This is normal Marine/Automotive battery and alternator voltage.	
Current:	The S-2 uses varying amounts of current depending on the status.	
	Monitoring mode, valve off (2 sensors)	400 mA max.
	Monitoring mode, valve on	1.20 A max.
	Alarm mode (valve off)	420 mA max.
Maximum Loads:	Valve control (current sink)	2.0 A max.
	Remote Horn (current sink)	200 mA max.
Valve Specs SV-1		0-312 PSI max

ELECTRIC SOLENOID VALVE SV-1

A. LPG (Propane) INSTALLATION

The electrical solenoid valve should be mounted on the tank side of the LPG Regulator, as close to the tank as practical. The tank itself should be mounted outside the cabin or crew quarters to avoid the possibility of gas accumulation due to a leak between the tank and solenoid valve.

B. CNG INSTALLATION

Because of the higher tank pressures of CNG, the solenoid valve MUST BE INSTALLED AFTER THE CNG REGULATOR and as close to the regulator as possible. The tank itself should be mounted outside the cabin or crew quarters to avoid the possibility of gas accumulation due to a leak between the tank and solenoid valve.

NOTE: AFTER INSTALLATION, ALL PIPE AND HOSE CONNECTIONS MUST BE CHECKED FOR LEAKS WITH A SOAPY WATER SOLUTION. NEVER USE A FLAME FOR LEAK TESTING.

3. OPERATION

When the installation has been completed the detection system is ready for operation.

Apply power to the S-2. Almost immediately both alarm lights will light and the siren will sound. Press the "MUTE" button to silence the siren. The alarm lights will remain on for approximately 15 seconds during which time the sensors are warming up. After the alarm lights have extinguished, the LPG/CNG valve may be energized by pushing the "VALVE ON/OFF" button. When this is done the valve will open and the light above the "VALVE ON/OFF" button will light indicating the valve is open and gas may flow. Push the same button again to turn the valve and light off when you no longer need the fuel to flow. THE S-2 WILL CONTINUE TO SENSE LPG/CNG AND/OR GASOLINE LEVELS AS LONG AS POWER IS APPLIED TO THE CONTROL MODULE.

The S-2 can be tested by pressing either the "TEST SENSOR 1" button or the "TEST SENSOR 2" button. The light above that button will light as long as the button is held down. If the button is held down for longer than 2 seconds the valve will close and the siren will sound. The "MUTE" button must be pushed to silence the audio alarm. To test the sensors for proper reaction to LPG/CNG and/or gasoline each sensor must be exposed to a small amount of the gas it was designed to detect. Direct the gas into the sensor which will cause the siren to alarm and the valve to close interrupting the flow of LPG/CNG. Following a brief interval the sensor will clear itself and the alarm light will extinguish. Whenever the S-2 closes the valve, it must be re-opened via the "VALVE ON/OFF" button but this is possible only after the alarm light goes out.

IMPORTANT — IN THE EVENT OF AN ALARM:

- A. Immediately have all passengers and crew exit the passenger compartment. If an explosion or fire should occur, the probability of injury will be greatly reduced if no one is in a confined area of the vessel.
- B. Determine which type sensor caused the alarm. If it was a gasoline sensor proceed to Step C. If the alarming sensor is a LPG/CNG sensor, open doors and windows for ventilation. Check for source of gas. Make sure valves are closed (off).
- C. Turn off motor and all electrical circuits. Do NOT turn on blower. Investigate the nature of the problem. If no smoke has appeared and the engine compartment is cool to touch, then visually inspect the engine compartment. If no smoke is present then it is reasonable to assume that fire is not the cause of the alarm. It is then safe to vent the engine compartment. After several minutes of ventilation the fumes should clear and the alarm light should extinguish.

NOTE: It is important to understand, however, that an alarm would not have occurred unless a problem had existed. Carefully check all fuel lines, gas lines, and other potential sources of gas leaks.

4. MAINTENANCE

The S-2 requires very little maintenance. Periodic visual inspection of the sensors for rough treatment, oil or grease deposits, or damage to the wires should be performed. Periodic activation of the test switches should also be performed to insure proper operation of the S-2 electronic circuitry.

NOTE: While it is reasonable to assume the sensors will have useful lives of 9 years or more, it is advisable to replace the sensors every 3 years due to harsh environmental conditions encountered in marine applications.

5. TROUBLESHOOTING

The most likely problem that will be encountered is continuous alarming. If this should occur and you are positive that there are no gas fumes present, check for recent use of solvent, paint or paint thinner, polish, etc. If none of these vapors are present, the next step is to thoroughly check the sensor wires for loose connections or broken wires. Since the sensors are part of a normally closed system non-continuous wires will cause an alarm.

The vapor sensors are best checked with a few simple voltage measurements. Connect the negative lead of a D.C. voltmeter to the brown wire (+12 Volt ground) of the control module and the positive lead of the voltmeter to the red wire (+12 Volt power) of the control module. There should be approximately 12 volts. If not, there is a problem with the power to the unit. Now move the positive lead of the voltmeter to the blue wire (sensor 1 and 2 high) of the control module. This should measure approximately 11 Volts (1 Volt less than the red wire). If not,

there is a problem with the control module itself. Move the positive lead of the voltmeter to the yellow wire (sensor 1 signal) of the control module which should measure approximately 2.5 Volts. If it is below 1.0 Volts or above 3.5 Volts the unit will alarm. **THE SENSOR MUST BE REPLACED IF THE MEASURED VOLTAGE IS OUTSIDE THIS RANGE WITH NO GASES PRESENT.** Finally, move the positive lead of the voltmeter to the violet wire (sensor 2 signal) of the control module and repeat the previous voltage measurement for the second sensor. In addition, if either "TEST SENSOR" button does not operate as explained in the operation section of this instruction sheet, the control module should be repaired or replaced.

NOTE: An occasional beep from the horn every 20 to 30 seconds indicates that the S-2 recognizes a low battery condition, and the battery system should be checked and/or charged to silence the horn.

DETECTS, INC. LIMITED PRODUCT WARRANTY

THIS WARRANTY IS IN LIEU OF ALL OTHER EXPRESS OR IMPLIED WARRANTIES

Seller warrants title, materials, and workmanship on equipment, except components manufactured by others for which Seller assigns, as permitted, the original manufacturer's warranty. Seller's warranty shall be for a period of one (1) year from the date of sale to the ORIGINAL CONSUMER PURCHASER, during which non-conforming equipment returned to Seller at Buyer's expense and risk shall be repaired or replaced at Seller's option. Detects, Inc. will repair or replace products found to be defective in materials or workmanship within the period set forth above, provided that:

- (a) the product has not been subjected to abuse, contamination, neglect, accident, incorrect wiring not our own, improper installation or servicing, or use in violation of instructions furnished by Detects, Inc., and,
- (b) as to any prior defects in materials or workmanship covered by this warranty, the product has not been repaired or altered by anyone except Detects, Inc., and,
- (c) the serial number has not been removed, defaced, or otherwise, changed, and,
- (d) examination discloses, in the judgement of Detects, Inc., a defect in materials or workmanship which developed under normal installation, use and service. Detects, Inc. does not assume the costs of removal and/or installation of the product or any other incidental costs which may arise as a result of any defect in materials or workmanship, and,
- (e) upon discovery of defect, buyer shall immediately cease use of the product and notify Detects, Inc.

ANY WARRANTY IMPLIED BY LAW, INCLUDING WARRANTIES OF MERCHANTABILITY OR FITNESS, IS IN EFFECT ONLY FOR THE DURATION OF THE EXPRESS WARRANTIES SET FORTH ABOVE.

NO PERSON IS AUTHORIZED TO GIVE ANY OTHER WARRANTY, OR TO ASSUME FOR DETECTS, INC., ANY OTHER LIABILITY IN CONNECTION WITH THE SALE OF ITS PRODUCTS.

DETECTS, INC. SHALL NOT BE LIABLE FOR THE LOSS OF USE, REVENUE, OR PROFIT OR FOR ANY INJURY, OR FOR ANY OTHER CONSEQUENTIAL OR INCIDENTAL DAMAGES.

BUYER IS NOT RELYING ON SELLER'S JUDGEMENT REGARDING HIS PARTICULAR REQUIREMENTS, AND HAS HAD AN OPPORTUNITY TO INSPECT THE PRODUCT TO HIS SATISFACTION.

SOLENOID VALVE

PART NUMBER: SV-1

SPECIFICATIONS:

OPERATING VOLTAGE	12 VDC
POWER REQUIREMENT	6 WATTS
TYPICAL CURRENT	0.6 AMPS
MAXIMUM PRESSURE	312 PSI
INLET & OUTLET PIPE THREADS	1/4" NP FEMALE PIPE

INSTALLATION:

A. LPG (Propane) INSTALLATION

The electric solenoid valve should be mounted on the tank side of the LPG Regulator, as close to the tank as practical. The tank itself should be mounted outside the cabin or crew quarters to avoid the possibility of gas accumulation due to a leak between the tank and solenoid valve.

B. CNG INSTALLATION

Because of the higher tank pressures of CNG, the solenoid valve **MUST BE INSTALLED AFTER THE CNG REGULATOR** and as close to the regulator as possible. The tank itself should be mounted outside the cabin or crew quarters to avoid the possibility of gas accumulation due to a leak between the tank and solenoid valve.

NOTE: AFTER INSTALLATION, ALL PIPE AND HOSE CONNECTIONS MUST BE CHECKED FOR LEAKS WITH A SOAPY WATER SOLUTION. NEVER USE A FLAME FOR LEAK TESTING.

Wiring is not polarized so connect one wire to +12 VDC and connect the other wire to the XINTEX S-2, S-2 LM, Control C-1, old Shadow and Control Series. The solenoid valve will open when the "Valve ON/OFF" button is pushed and will close when the button is pushed a second time.

March, 1989

ADDENDUM FOR "SENSOR SIMULATOR" CONNECTION
ON XINTEX MODELS: M-2, S-2 AND S-2LM.

- There has been an engineering change to
- the sensor simulator provided with this Vapor Monitor system. The sensor simulator described in the owners manual contained 5 wires. 3 wires (Red, Green, and Brown) were connected. 2 wires (White and Black) were left unconnected. The new simulator contains only 3 wires (Red, Green, and Black). The Red and Green wire connect as before (see fig. 3) and the Black wire connects to terminal where Brown is indicated on the drawing.